

PNS Algorithm and Simulink Design of Wireless OFDM ICS Repeater with Phase Noise

Chisato Iramina*, Tomohisa Wada*, Heung-Gyoon Ryu**

*Department of Information Engineering, University of the Ryukyus,

chisato@lsi.ie.u-ryukyu.ac.jp, wada@ie.u-ryukyu.ac.jp

**Department of Electronic Engineering, Chungbuk National University, ecommm@cnu.ac.kr

Abstract – In this paper, we have studied an ICS repeater based on OFDM system considered with phase noise effects by using Simulink. In wireless repeater system, in case of same frequency for transmitted and received signals, the feedback interference signal, which comes into the receive antenna from the transmit antenna of a radio repeater, causes the radio repeater go into feedback oscillation when the gain of a radio repeater is larger than the isolation. In addition, system performance will get worse if there are phase noise effects. Therefore, we propose adaptive feedback channel equalizer and phase noise compensator based on OFDM system in order to reduce feedback channel and phase noise effects. As a results of simulation using by Simulink, we found that ICS repeater with adaptive feedback equalizer and phase noise compensator shows much better performance than without phase noise suppression in case of QPSK and 16QAM. In QPSK, it showed about 5~6dB improvement, and types of 16QAM works about 7~8dB improvement.

Keywords: OFDM System, Simulink, ICS, Phase Noise, Interference cancellation, Canceller.

1 Introduction

In case of same frequency for transmitted and received signals in a radio repeater, the feedback interference signal, which comes into the receive antenna from the transmit antenna of a radio repeater, causes the radio repeater go into feedback oscillation when the gain of a radio repeater is larger than the isolation.

Some feedback interference cancellation system (ICS) to increase the isolation between the transmitting and the receiving antennas of radio repeaters have been reported [1]-[5]. Among them, analog ICS cancel the feedback signal using a generated signal with the same amplitude and anti-phase as the feedback signal [1]-[2]. Digital ICS based on an adaptive filter have also been implemented [3]-[5].

Such previous researches weren't considered with phase noise effect. Phase noise which is generated in the base station's transmitter and repeater's transceiver oscillators causes the system performance seriously degradation. Because of this, in this paper, we designed wireless ICS repeater considered with phase noise compensation system model for a radio repeater which is based on OFDM wireless communication system. In order to design more realistic environment, Simulink is used. And we use phase noise suppression (PNS) algorithm for phase noise effect cancelling.

2 System Description of Repeater

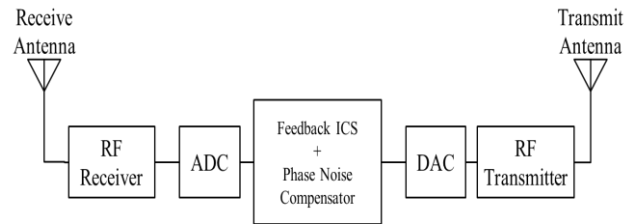

Fig.1. Structure of an ICS repeater.

The simplified structure of a repeater which has an interference cancellation system (ICS) can be showed in Figure 1. Repeater is composed of a radio frequency (RF) receiver, and ADC, a digital interference cancellation system, a DAC and a RF transmitter. RF receiver executes pre-processing such as amplification, frequency down conversion to an intermediate frequency (IF), and ADC converts the IF analog signal to a digital signal. Feedback ICS and Phase noise compensator are performed in the digital domain. DAC again transforms the digital signal to IF analog signal. RF transmitter performs post-processing such as filtering, frequency up conversion to RF, and power amplification to radiate the RF signal into the air.

In wireless repeater system, effects of phase noise exist in each transmitter and receiver oscillators. In order to cancel feedback and phase noise interference, we use feedback channel equalizer and phase noise canceller in digital domain. In this paper, we consider such this repeater based on OFDM system.

3 Equalizer and Phase noise Canceller

Figure 2 shows a structure of feedback channel model, phase noise and its solution of wireless ICS repeater. Input signal $i(n)$ represents a signal that comes from a base station. $i(n)$, feedback signal y_F that comes from repeater's transmitter and phase noise $e^{j\phi(n)}$ which is generated in its receiver oscillator mixed in the repeater. In order to solve feedback interference and phase noise effects, adaptive feedback channel equalizer and phase noise compensator inserted in the repeater system. Structure of adaptive feedback channel equalizer and phase noise compensator contains feedback path. But, it is possible with low the number of tap than FIR filter.

In this paper, we use preamble in order to estimate feedback channel. First, we send preamble and then we estimate feedback channel. After that, we cancel the effect of phase noise by using phase noise compensator. And we estimate feedback channel by using minimum mean square error (MMSE).

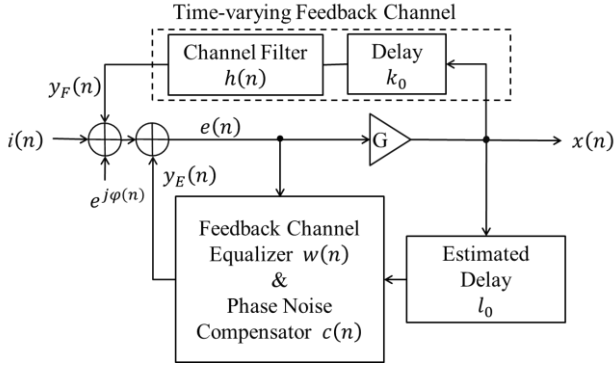

Fig. 2. Structure of proposed ICS repeater.

The feedback signal y_F can be expressed by (1).

$$y_F(n) = h(n) * x(n - k_0). \quad (1)$$

where $*$ denotes the convolution, and k_0 means delay. To cancel the feedback signal y_F , we need to estimate feedback signal. The estimated feedback signal y_E is generated by such as

$$y_E(n) = w(n) * c(n) * x(n - l_0). \quad (2)$$

where l_0 is the estimated delay of the dominant feedback signal, and the error signal $e(n)$ is given by

$$\begin{aligned} e(n) &= i(n) \cdot e^{j\phi(n)} + y_F(n) \cdot e^{j\phi(n)} - y_E(n) \\ &= i(n) \cdot e^{j\phi(n)} + [h(n) - w(n) * c(n)] \cdot e^{j\phi(n)} * x(n - k_0) \end{aligned} \quad (3)$$

where $e^{j\phi(n)}$ denotes phase noise. Therefore, the output signal can be expressed by

$$\begin{aligned} x(n) &= G \cdot e(n) \\ &= G \cdot i(n) \cdot e^{j\phi(n)} + G \cdot [h(n) - w(n) * c(n)] \cdot e^{j\phi(n)} * x(n - k_0) \end{aligned} \quad (4)$$

where G indicates the repeater's gain.

The iterative algorithm to minimize the mean square of the error $e(n)$ for canceling interference can be applied such as least mean square (LMS) algorithm. MMSE can be expressed by

$$\begin{aligned} E\{e^2(n)\} &= E\left\{\left[i(n) \cdot e^{j\phi(n)} + y_F(n) \cdot e^{j\phi(n)} - y_E(n)\right]^2\right\} \\ &= E\left\{\left[i(n) \cdot e^{j\phi(n)}\right]^2\right\} + E\left\{\left[y_F(n) \cdot e^{j\phi(n)} - y_E(n)\right]^2\right\} \\ &\quad - 2E\left\{i(n) \cdot e^{j\phi(n)} \left[y_F(n) \cdot e^{j\phi(n)} - y_E(n)\right]\right\} \end{aligned} \quad (5)$$

Adaptive channel tap updater, $w(n)$ is calculated by

$$w(n+1) = w(n) + \mu e(n) x(n - l_0). \quad (6)$$

where μ is a parameter to control the convergence rate and excess mean square error of LMS. After cancelling feedback interference, we can obtain such as

$$\tilde{e}(n) = i(n) \cdot e^{j\phi(n)}. \quad (7)$$

Above equation is still existing phase noise effect. So, we have to talk about PNS algorithm. Phase noise has two components. One is common phase error (CPE) that works as the rotation factor of original signal. The other is inter-carrier interference (ICI). So, PNS algorithm can be divided into two parts of compensation methods, CPE compensation and ICI cancellation. First, we compensate CPE component. After that, ICI will be cancelled.

Received signal which is canceled feedback channel n th data sample of m th OFDM symbol can be expressed as follows:

$$\begin{aligned} E_m(k) &= \sum_{n=0}^{N-1} \tilde{e}_m(n) \cdot e^{j\frac{2\pi}{N}kn} = \frac{1}{N} \sum_{n=0}^{N-1} \left\{ i_m(n) \cdot e^{j\phi_m(n)} \right\} \cdot e^{j\frac{2\pi}{N}kn} \\ &= \frac{1}{N} \sum_{l=0}^{N-1} \sum_{n=0}^{N-1} I_m(l) \cdot e^{j\phi_m(n)} \cdot e^{j\frac{2\pi}{N}(l-k)n} \\ &= I_m(k) + \left(j I_m(k) \cdot \frac{1}{N} \sum_{n=0}^{N-1} e^{j\phi_m(n)} \right) + \left(\sum_{l=0}^{N-1} I_m(l) \cdot \frac{1}{N} \sum_{n=0}^{N-1} e^{j\phi_m(n)} e^{j\frac{2\pi}{N}(l-k)n} \right) \\ &= I_m(k) + CPE + ICI \end{aligned} \quad (8)$$

where N is the total sub-carrier number. CPE can be estimated by using pilots. CPE component can be detected as follows.

$$CPE_m(k) = \frac{Y_m(k)}{X_m(k)} = Q_m(0) + \frac{ICI + V_m(k)}{X_m(k)} = Q_m(0) + W_{interference}(k) \quad (9)$$

where $X_m(k)$ denotes transmitted pilot and $Y_m(k)$ is received pilot, $Q_m(0)$ is CPE and $ICI = \sum_{l=-N/2, l \neq k}^{N/2-1} X_m(l)Q_m(l-k)$ and $W_{interference}(k)$ is total interference component caused by ICI and AWGN.

Finally, the average CPE r_{cpe} is detected by averaging the whole pilot carriers.

$$r_{cpe} = \frac{1}{N_p} \sum_{k \in S_p} CPE_m(k) = Q(0) + \frac{1}{N_p} \sum_{k \in S_p} W_{interference}(k) \quad (10)$$

By this averaging operation, the ICI contribution in CPE estimation can be decreased. After CPE compensation, the received signal is possible to be expressed as follows.

$$\begin{aligned} \tilde{E}_m(k) &= I_m(k) + \left(\sum_{l=0}^{N-1} I_m(l) \frac{1}{N} \sum_{n=0}^{N-1} e^{j\phi_m(n)} e^{j\frac{2\pi}{N}(l-k)n} \right) \\ &= I_m(k) + \left(\sum_{l=0}^{N-1} I_m(l) Q_m(l-k) \right) \\ &= I_m(k) + ICI \end{aligned} \quad (11)$$

Due to the influence of ICI with Gaussian noise property, the phase noise effect is compensated only a certain extent during CPE estimation. In order to compensate phase noise influence ICI, MMSE equalizer is used. $C'_m(k)$ is obtained by MMSE algorithm as follows.

$$C'_m(k) = \frac{\tilde{Q}_m^*(0) H_m^*(k)}{\left| \tilde{Q}_m(0) H_m(k) \right|^2 + \frac{\tilde{\sigma}_\varepsilon^2(m)}{E_x}} \quad (12)$$

where $\tilde{\sigma}_\varepsilon^2(m)$ is the variance of $W_{ICI+AWGN}$.

In above equation $\tilde{Q}_m(0)$ and $\tilde{\sigma}_\varepsilon^2(m)$ are needed. The power $\tilde{\sigma}_\varepsilon^2(m)$ of $W_{ICI+AWGN}$ is obtained as follows. $\tilde{\sigma}_\varepsilon^2(m)$ of data sub-carriers can be approximated by estimating $\tilde{\sigma}_\varepsilon^2(m)$ in pilot sub-carriers that is compensated CPE component.

$$\hat{\sigma}_\varepsilon^2(m) = \frac{1}{N_N} \sum_{k \in S_p} \left| \tilde{Y}_m(k) \right|^2 \quad (13)$$

$\tilde{Q}_m(0)$ can be achieved by the method of minimizing cost function using pilot samples as follows:

$$\tilde{Q}_m(0) = \frac{\sum_{k \in S_p} \tilde{Y}_m(k) X_m^*(k) H_m^*(k)}{\sum_{k \in S_p} |X_m(k) H_m(k)|^2} \quad (14)$$

After estimation of $\tilde{Q}_m(0)$ by using above equation, more practical factor can be achieved using decision feedback process as follows.

$$\hat{Q}_m(0) = \gamma \tilde{Q}_m(0) + (1-\gamma) \tilde{Q}_m^*(0) \quad (15)$$

where γ is a forgetting factor that is able to express by (16)

$$\gamma = \frac{1}{N_p} \sum_{k \in S_p} |X_m(k) - \tilde{Y}_m(k)|^2 \quad (16)$$

\tilde{Q}_m^* can be achieved as the form of (14) except that detected data sample S_D is used for estimation.

Finally, the transmitted data sample is detected as follows.

$$\hat{I}_m(k) = \tilde{E}_m(k) \cdot C'_m(k) \quad (17)$$

4 Simulink Design and Simulation

Figure 3 and 4 show the system design with PNS algorithm process by Simulink.

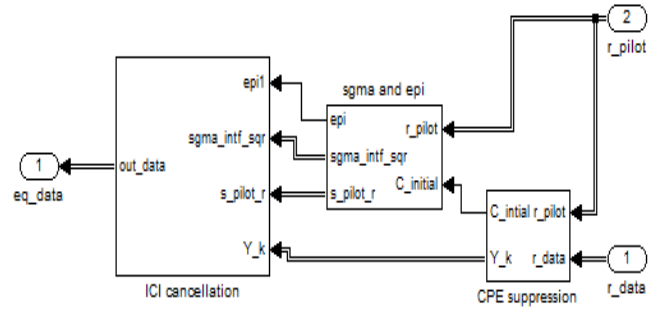

Fig. 3. CPE and ICI cancellation by Simulink.

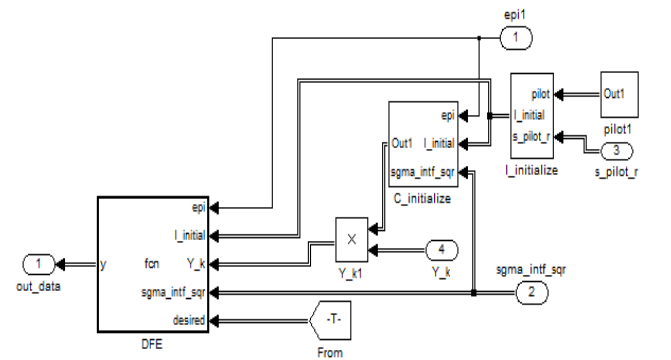

Fig. 4. Details of ICI cancellation part in PNS.

To analyze and compare the system performance, some computer simulations have been preceded by Simulink. Simulation parameters are as following Table 1.

Table 1. Simulation parameters.

Conditions	
Carrier Modulation	QPSK, 16QAM
Subcarrier Numbers	64
Data Subcarrier	48
FFT/IFFT size	64
Cyclic Prefix	16 (1/4 per OFDM symbol)
Channel	AWGN + Feedback
Delay	8
Data Format	IEEE 802.11a WLAN.
Phase Noise	-15dBc , cut-off=10kHz

From the above simulation parameters, system performances have been analyzed in the IEEE 802.11a WLAN standard OFDM system. In this simulation, we assumed that data transmission time is short and channel is not largely change during data transmission time. Therefore, we can get channel impulse response by preamble. So, feedback channel estimation is perfect. Figure 5 and Figure 6 The result of BER performance on QPSK and 16QAM. Black line is theoretical AWGN channel, red-solid line is without any equalization, green dash lines is only feedback cancellation, and blue dash-dotted line is all compensation. According to Figure 5, ICS repeater with adaptive feedback equalizer and phase noise compensator shows much better performance than without phase noise suppression in case of QPSK. It works about 4~5dB improvement. And according to Figure 6, ICS repeater with adaptive feedback equalizer and phase noise compensator shows much better performance than without phase noise suppression in case of 16QAM. It works about 7~8dB improvement.

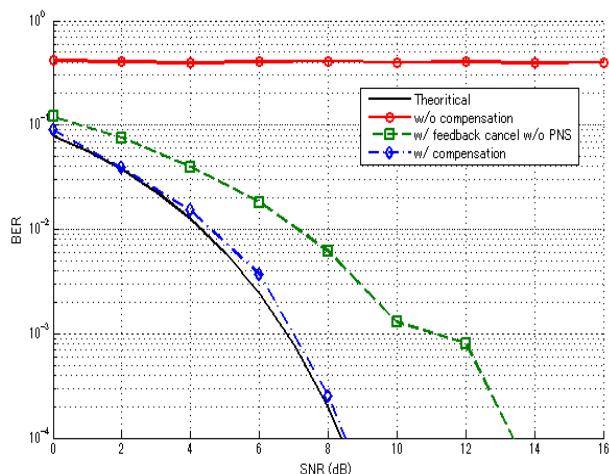

Fig. 4. The result of BER performance on QPSK.

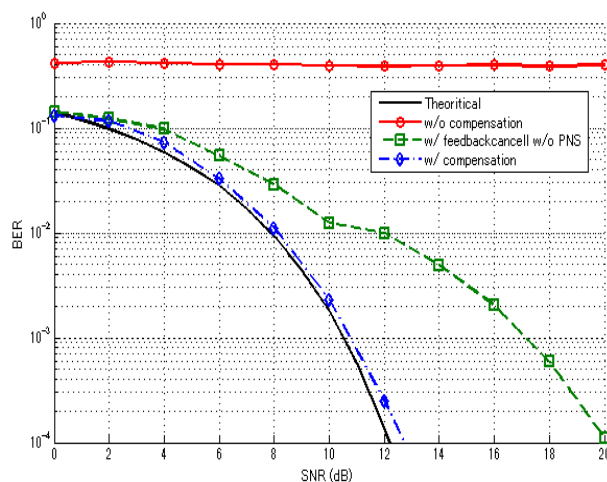

Fig. 5. The result of BER performance on 16QAM.

5 Conclusions

In this paper, we have studied an ICS repeater based on OFDM system considered with phase noise effects by using Simulink. In wireless ICS repeater system, system performance will get worse if there are phase noise effects. Therefore, the phase noise suppression algorithm is needed in wireless ICS repeater. In order to cancel feedback channel and phase noise effects, we propose a feedback channel equalizer and phase noise compensator with PNS algorithm. By using such algorithms we designed repeater by using Simulink and evaluated its performance. In this simulation, it assumed that channel estimation is perfectly worked. According to this simulation results, all compensation method works well.

References

- [1] S. J. Kim, J. Y. Lee, J. C. Lee, J. H. Kim, B. Lee, and N. Y. Kim, "Adaptive feedback interference cancellation system (AF-ICS)", IEEE Microwave Symposium (MTT-S) Digest, pp. 627-630, 2003.
- [2] J. Lee; S. Park; H. Choi; Y. Jeong; J. Yun; "A design of co-channel feedback interference cancellation system using analog control", Microwave Conf., 36th European, September 2007.
- [3] W. Moon; S. Im; and C. Kim; "Adaptive feedback interference cancellation using correlation for WCDMA wireless repeaters" *The really Institute of Electronics Engineers of Korea, Journal*, Vol. 44, No. 7, issue 7, July, 2007
- [4] T. Yoon, D. Woo, J. Kim, S. Ha, J. Van, and J. Lee, "Wireless repeating interference cancellation using signed DLMS adaptive algorithm" *The institute of Electronics Engineers of Korea, conference & Workshop*, vol. 30, issue 1, July, 2007
- [5] D. Choi, H. Yun, "Interference cancellation repeater," PCT Patent WO 2007/078032 A1, July, 2007