

A 31.8kbps/8kHz Underwater Acoustic Single Carrier Frequency Division Multiplexing (SC-FDM) Communication System with Forward Error Correction

Taisaku Suzuki^{1), 2)}

¹⁾ Graduate School of Engineering and Science,
University of the Ryukyus,
Senbaru 1, Nishihara, Okinawa, Japan

²⁾ National Institute of Technology,
Okinawa College

Henoko 905, Nago-shi, Okinawa, Japan
suzuki.t@okinawa-ct.ac.jp

Tomohisa Wada

Dept. of Information Engineering,
University of the Ryukyus,
Senbaru 1, Nishihara, Okinawa, Japan
wada@ie.u-ryukyu.ac.jp

Hiromasa Yamada, Shigeo Nakagawa

Oki Seatec Co., Ltd.
Uchiuramito 537-5, Numazu-shi,
Shizuoka, Japan
yamada882@oki.com,
nakagawa153@oki.com

Abstract— This paper proposes an underwater acoustic Single Carrier Frequency Division Multiplexing (SC-FDM) communication system with a forward error correction to transmit image or movie data packet from deep sea ROV (Remotely operated vehicle) etc. to surface ship. Since the SC-FDM is basically Orthogonal Frequency Division Multiple Access (OFDM) with pre- and post-coding, frequency bandwidth is efficiently utilized to deliver high data bandwidth as well as lower Peak-to-Average-Power Ratio (PAPR) of the transmitting signal. In order to realize error-free communication adaptively to wide range of Carrier signal to Noise power Ratio CNRs, 3 carrier modulations such as QPSK / 16QAM / 64QAM and 5 code rates are supported. Using 64QAM with code rate $R=7/8$, a 31.8 kbps in 8kHz maximum channel bandwidth has been achieved. The system utilized 20-28 kHz and subcarrier spacing of 50 Hz. Total number of sub-carriers is 161. The system is verified by Ocean experiment at Suruga Bay with 1000m deep sea in Shizuoka, Japan. At the depth of 100m, with 64QAM and code rate $R=3/4$ (Rate=27.241 kb/s), Packet Error Rate (PER) =0 % is observed. At the depth of 400m, with 64QAM and $R=2/3$ (Rate=24.213 kb/s), PER=0 % is also achieved. At the depth of both 700 and 1000m, with 16QAM and code rate $R=2/3$ (Rate=16.140 kb/s), PER closed to 0 % is realized.

Keywords—Underwater, Acoustic Communication, SC-FDM, PAPR, Doppler compensation, Convolutional code, Viterbi decode

I. INTRODUCTION

Underwater acoustic wireless communication is needed to transmit the digital data between marine equipment. The examples are image or movie data transmission from deep ROV or AUV (autonomous underwater vehicle) to surface ship, control data transfer in the opposite direction, information exchange between divers, collecting biological information data necessary to manage the safety diving etc. as shown in Fig. 1. In order to realize such digital data transfer, transmitted data packets should be error-free for various channel distances and SNR (signal to noise power ratio) conditions. Then, error correction capability has to be integrated in the underwater communication system.

In this paper, we propose an underwater acoustic SC-FDM [1] communication system with forward error correction (FEC). The components of the FEC are convolutional encoder [2] and

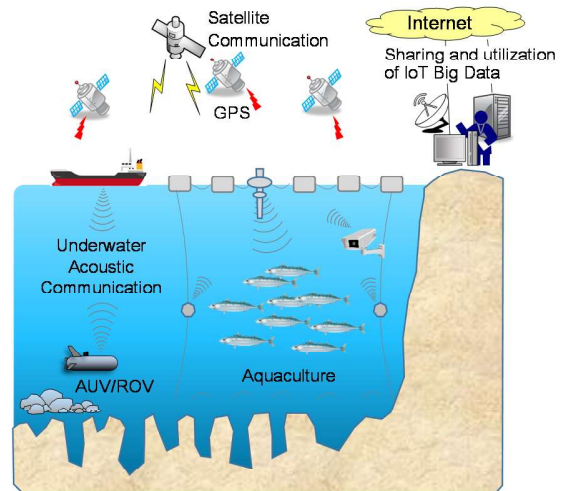

Fig. 1: Target application of SC-FDM communication system.

data interleaver for transmitter side, and soft input Viterbi decoder [2] and data de-interleaver for receiver side. The modulation and de-modulation of SC-FDM core is based on the OFDM communication system disclosed in the paper [3], which has the additional time domain signal processing such as signal shrink-expansion processing and phase shift compensation in order to mitigate Doppler shift effect. In addition, the core includes 4 branches receivers and Maximum-Ratio Combining (MRC) diversity to improve Carrier to Noise power Ratio (CNR) by 6dB in order to extend communication range.

The section II describes the proposed SC-FDM system architecture and channel coding processing. The section III shows obtained basic system performance. Ocean field experiment results are shown in section IV. Finally, the summary is concluded in section V.

II. PROPOSED SYSTEM

A. System Block Diagram

Fig.2 shows the block diagram of proposed underwater acoustic SC-FDM communication system with FEC. The lower

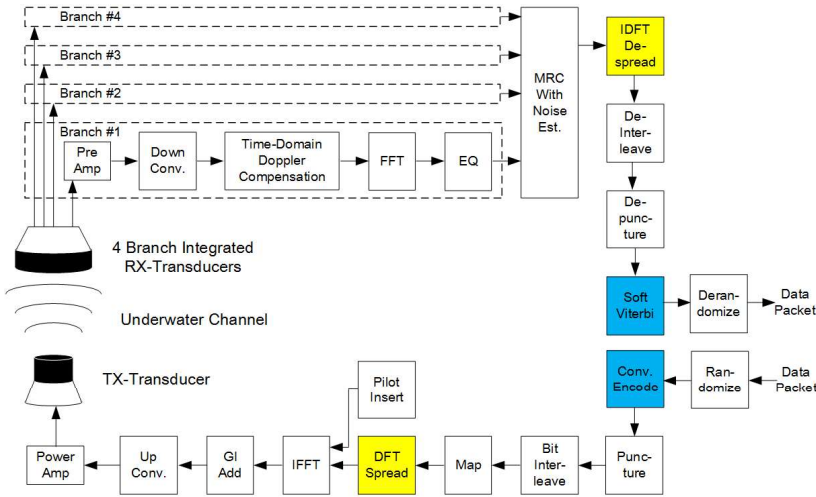

Fig. 2: Block Diagram of SC-FDM Communication System with Forward Error Correction. Lower side is transmitter while upper side is 4 branch diversity receiver.

side of the figure corresponds to the transmitter TX and the upper side is receiver RX. The TX modulation is typical OFDM transmitter with DFT pre-code, while the RX demodulation has additional Time-Domain Doppler compensation capability. In TX side, bit data are first randomized to have similar numbers of '0's and '1's distributions. Then channel encoder of convolutional code is used to generate 2 times larger data sequence, which corresponds to code rate $R=1/2$. After the coding, some of sequence are punctured to reduce the size of sequence in order to increase code rate $R=1/2$ to $2/3$, $3/4$, $5/6$, $7/8$. The output sequence of puncture block are bit-interleaved. Then the outputs are modulated by using QPSK / 16QAM / 64QAM digital modulations and Discrete Fourier Transform (DFT) is applied to spread the sequence. Then, IFFT modulation is performed for combination of the DFT-spread sequence with Zadoff-Chu sequence [4] pilot. Guard Interval (GI) of 2.8125 ms is attached to the head of each symbol. The GI length is carefully determined by taking multi-path delay distribution. Then the baseband signal is up-converted to 24 kHz center frequency, and finally the output of TX is emitted into underwater channel via TX transducer with average power of 166dB. Summary of the system features are shown in Table I.

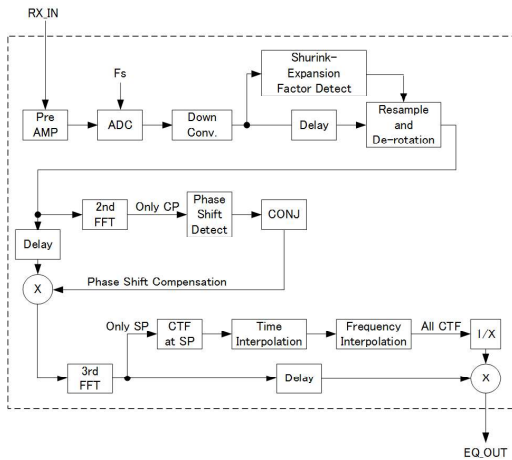

Fig. 3: Block diagram of 1 branch receiver.

TABLE I : SC-FDM SYSTEM FEATURE

Parameters	Value
TX-RX Elements	1 TX and 4 RX Transducer
Sampling Frequency	102.4 kHz
Transmission Band	20 – 28 kHz
FFT Size	2048 points
SC-FDM symbol length T	20.0 ms
GI length T_g	2.8125 ms (288 points)
Sub Carrier Spacing	50 Hz
Number of Sub Carrier	161
Packet length	49 symbols = 1.12 s
Carrier Modulation	QPSK / 16QAM / 64QAM, BPSK(only control)
Interleaver Size	564 Carrier Symbol
Channel Coding	Convolutional Code
Constraint Length K	7
Code Rate R	$1/2$, $2/3$, $3/4$, $5/6$, $7/8$
Max. Data Rate with FEC	31.8 kbps (64QAM, $R=7/8$)
Average TX power	166dB

Fig. 3 shows the block diagram of one branch receiver in detail. The Time-Domain Doppler compensation block in Fig. 2 corresponds to Shrink-Expansion Factor detect, Resample/De-rotation, and Phase Shift Compensation [3]. Those two stages signal processing have realized robust Doppler immunity which can use even 64QAM higher modulation. After the Phase-Shift compensation, 3rd FFT is performed. Then channel estimation processing is performed to generate a channel transfer function (CTF). By dividing the 3rd FFT output by CTF, equalization process is performed to recover correct constellations. Finally, Maximum-Ratio Combining (MRC) [5,6] is performed for diversity combining by using 4 RX outputs as shown in Fig.2.

B. Time-Frequency Representation

Fig. 4 shows the time-frequency representation of system. The number of total sub-carriers in one SC-FDM symbol is 161. The 41 Scattered Pilot (SP), which are placed at all every four sub-carriers, are allocated to one SC-FDM symbol in every 4 SC-FDM symbol intervals as shown by the triangle. The SP is

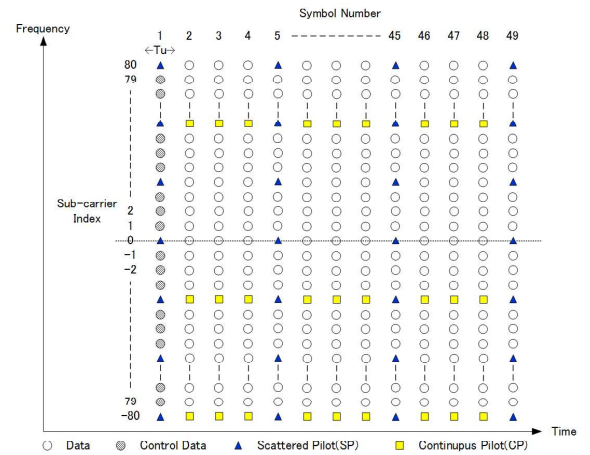

Fig. 4: Time-Frequency representation of SC-FDM system. Every four symbol, Scattered Pilots (SPs) are placed and they are used to calculate Channel Transfer Function and Delay.

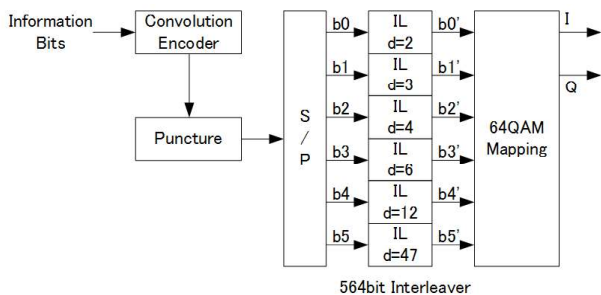

Fig. 5: Transmitter's Channel coding, Puncturing and Bit Interleaving for 64QAM modulation. Each interleaver size is 564 bit, which corresponds to 4 SC-FDM symbols.

used for channel estimation to generate channel transfer function (CTF). In order to obtain whole time-frequency grid CTF values, CTF at SP position are interpolated in time and frequency axis. The 13 symbols of Continuous Pilot (CP) are allocated to each SC-FDM symbol randomly among indices of SP as shown as rectangle. The CP is used to calculate fine Phase Shift Estimation for phase compensation. The other white circles correspond to data sub-carriers, which are modulated by QPSK / 16QAM / 64QAM. At the first SC-FDM symbol, the gray circles are used to send control data such as modulation and code rate R, which is modulated by BPSK.

C. Channel coding, Puncturing and Bit Interleaving

If the communication system is applied to rich living creature marine environment, it suffers from generated Impulsive Noise so-called Shrimp Noise, which is randomly generated in time domain and seriously degrades communication performance in underwater acoustic network [6,7]. Then bit interleaver is introduced to spread burst errors to random errors so that the Viterbi decoder can correct more errors.

Transmitter's Convolutional Encoder, Puncturing and Bit Interleaver for 64QAM modulation are shown in Fig. 5. Since every 6 bits b_0 to b_5 corresponds to one symbol in case of 64QAM, each b_0 to b_5 is interleaved with different interleave step such as $d=2/3/4/6/12/47$, respectively. The size of each bit interleaver is 564 bits, which corresponds to 4 SC-FDM

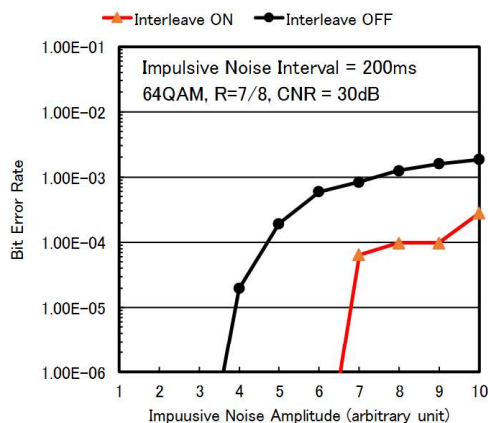

Fig. 6: Simulated Bit Error Rate comparison for 64 QAM modulation with and without Impulsive noise. By using interleaver, Immunity to impulsive noise is increased.

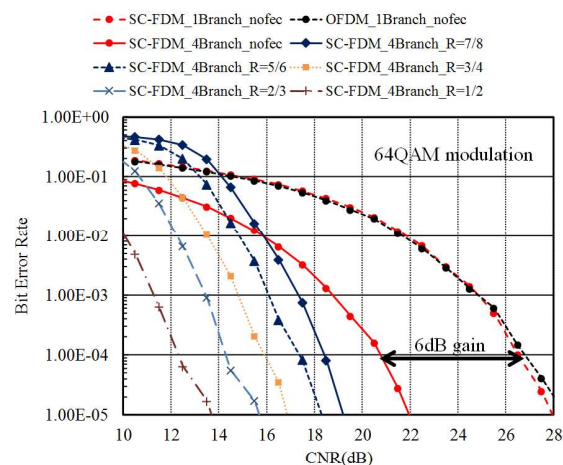

Fig. 7: Measured BER vs Carrier to Noise power Ratio (CNR) of 64QAM with and without FEC. By using 4 branch diversity, 6dB gain is obtained without FEC. By applying convolutional code with variety of code rate R, additional CNR gains are obtained.

symbols. This means interleaving period is confined within 4 SC-FDM symbols.

III. COMMUNICATION SYSTEM CHARACTERISTICS

Fig. 6 shows the simulated Viterbi decoder output's BER comparison for 64QAM modulation with and without Impulsive noise, which interval is 200 ms and peak level is varied as a parameter. By enabling the bit-interleaver, Immunity to impulsive noise level has been increased by twice and saturated error level is also decreased by one order of magnitude.

Fig. 7 shows a measured BER for 64QAM in laboratory water pool. The diversity gain of 6dB by 4 branch MRC algorithm was confirmed. By applying the convolutional code, the larger the code rate becomes, the smaller minimum CNR of error free region has been obtained. By the combination of modulation type and code rate R, error free packet can be transmitted in wide range of channel condition.

The Simulated Peak-to-Average-Power Ratio (PAPR) comparison between SC-FDM and OFDM are shown in Fig. 8.

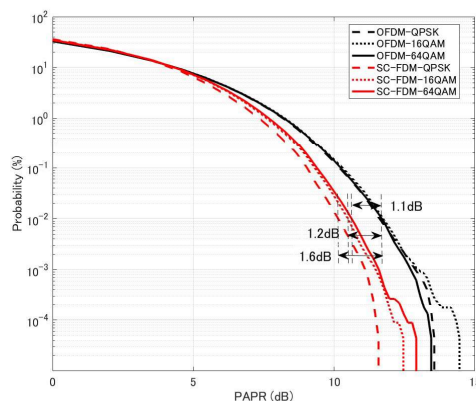

Fig. 8: Simulated Peak to Average Power Ratio of both SC-FDM and OFDM. By applying DFT pre-code, PAPR is reduced by 1.1 to 1.6dB.

The vertical axis is the probability of the transmitting signal's PAPR. At the 0.01 %, 1.6 to 1.1 dB reduction is obtained. This reduction enables to enlarge the transmitter power with avoiding power amplifier saturation to expand communication range.

IV. OCEAN EXPERIMENT RESULTS

Ocean experiment was performed at Suruga Bay in Shizuoka prefecture, Japan as shown in Fig. 7. The depth at experiment point is roughly 1100 m. Fig. 10(a) show a transmitter system. The top black portion is transducer and the red case includes high-pressure glass container, which carries control system and transmitting signal processing H/W. Fig. 10(b) is a receiver transducer. The black surface receives the underwater acoustic signal. Four of transducers are integrated at the black surface. In order to monitor real time acoustic signal and demodulated constellations, signal processing H/W is separately placed in mother ship in the experiment. The Transmitter system was submerged to 100 / 400 / 700 /1000m depth to monitor constellation and packet error rates (PERs).

Fig. 11 shows 64QAM measured constellation at 100 m depth. Although the rocking of the ship is happening, stable constellation has been obtained. Without the Doppler compensation mechanism [3], such clear constellation cannot be observed. Fig. 12 shows 16QAM constellation for 100m and 700 m depth, respectively. Because of the degradation of signal



Fig. 9: Ocean experiment was performed at Suruga Bay with 1100m deep.



Fig. 10(a): Transmitter system. The top black portion is transducer and red case includes control system and signal processing H/W.



Fig. 10(b): 4 branches integrated receiver transducer. For debugging purpose, Signal processing H/W is separately placed in ship.

power in proportional to depth, 16 QAM constellation of 700m gets broaden.

The packet length is 49 SC-FDM symbol, that is 1.12 s. The table II indicates how much information bits can be transferred in one packet and data rate in kbit/s. Maximum 31.782 kb/s at 64QAM with $R=7/8$ to lowest 6.049 kb/s at QPSK with $R=1/2$ are supported. Finally, Fig. 13 shows a graph on Packet Error Rate (PER), which is what percentage of the packets are error-free out of total number of packets. At the depth of 100m, with 64QAM and code rate $R=3/4$ (Rate=27.241 kb/s), PER=0 % is observed. At the depth of 400m, with 64QAM and $R=2/3$ (Rate=24.213 kb/s), PER=0 % is also achieved. At the depth of both 700 and 1000m, with 16QAM and code rate $R=2/3$ (Rate=16.140 kb/s), PER closed to 0 % is realized.

V. CONCLUSION

An underwater acoustic Single Carrier Frequency Division Multiplexing (SC-FDM) communication system with a forward error correction is designed and fabricated. Target of the system is to transmit image or movie data packet from deep sea ROV etc. to surface ship. By utilizing DFT pre-code, 1.1 to 1.6 dB lower PAPR is realized with SC-FDM comparing with OFDM.

In order to realize error-free communication adaptively to wide range of CNRs, 3 carrier modulations such as QPSK /

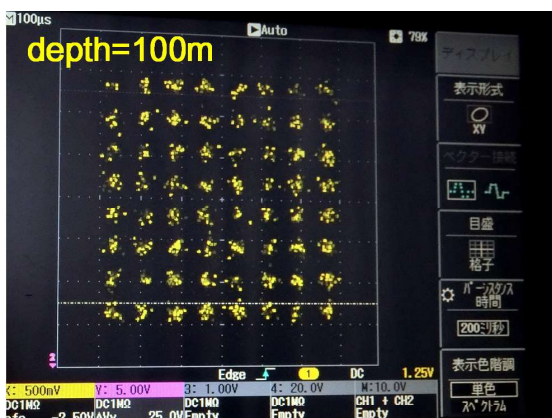

Fig. 11: Measured 64QAM constellation at 100m depth.

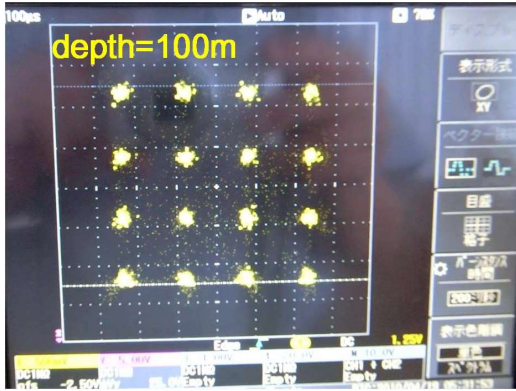

Fig. 12(a): Measured 16QAM constellation at 100m depth.

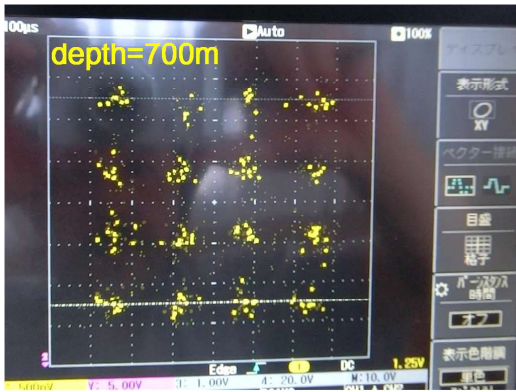

Fig. 12(b): Measured 16QAM constellation at 700m depth.

16QAM / 64QAM and 5 code rates are supported. Using 64QAM with code rate $R=7/8$, a 31.2 kbps in 8kHz maximum channel bandwidth could be achieved. The system utilized 20-28 kHz and subcarrier spacing of 50 Hz. Total number of subcarriers is 161.

The system is verified by Ocean measurement at Suruga Bay in Shizuoka prefecture, Japan. By performing experiment in the ocean at depth of 100 to 1000m, various low Packet Error Rates (PERs) have been obtained. At the depth of 100m, with 64QAM

TABLE II : TRANSMISSION RATE

Modulation	Code Rate	Packet Size (kb)	Rate (kb/s)
QPSK	1/2	6.762	6.049
	2/3	9.018	8.068
	3/4	10.146	9.077
	5/6	11.274	10.086
	7/8	11.838	10.590
16QAM	1/2	13.530	12.104
	2/3	18.042	16.140
	3/4	20.298	18.159
	5/6	22.554	20.177
	7/8	23.682	21.186
64QAM	1/2	20.298	18.159
	2/3	27.066	24.213
	3/4	30.450	27.241
	5/6	33.834	30.268
	7/8	35.526	31.782

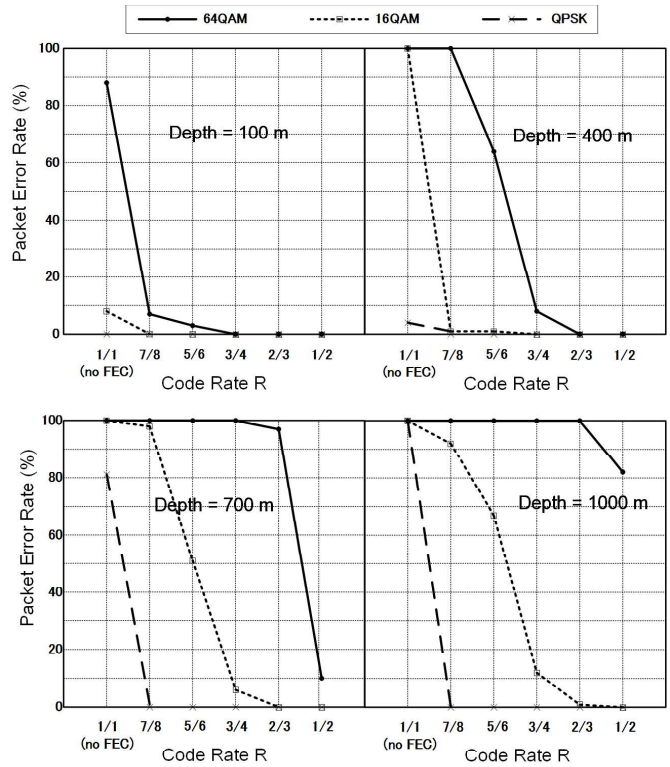

Fig. 13: Measured Packet Error Rate (%) for three modulation QPSK / 16QAM / 64QAM and for depths 100 / 400 / 700 / 1000 m.

and code rate $R=3/4$ (Rate=27.241 kb/s), PER=0% is observed. At the depth of 400m, with 64QAM and $R=2/3$ (Rate=24.213 kb/s), PER=0% is also achieved. At the depth of both 700 and 1000m, with 16QAM and code rate $R=2/3$ (Rate=16.140 kb/s), PER closed to 0% is realized.

REFERENCES

- [1] Sassan Ahmadi, LTE-Advanced A Practical Systems Approach to Understanding 3GPP LTE Releases 10 and 11 Radio Access Technologies, ACADEMIC PRESS, 2014, pp.724-734.
- [2] Todd K. Moon, ERROR CORRECTION CODING Mathematics Methods and Algorithms, WILEY, 2005, pp.452-486.
- [3] Taisaku Suzuki, Tomohisa Wada, Hiromasa Yamada, and Shigeo Nakagawa, "An Underwater Acoustic 64QAM OFDM Communication System with Robust Doppler Compensation," MTS/IEEE OCEANS 2016, Monterey, CA, USA, September 19-23rd 2016.
- [4] Stefania Sesia, Issam Toufik, Matthew baker, LTE The UMTS Long Term Evolution FROM THEORY TO PRACTICE, WILEY, 2009, pp.145-150.
- [5] Hai, Tran Minh, et al. "Ultrasonic Diversity OFDM transceiver architecture with impulsive noise cancelling for shallow sea communication," 2nd Underwater Acoustics Conference and Exhibition UA2014, June 22nd to 27th, 2014, Rhodes, Greece, page 1227-1232,
- [6] Rie Saotome, Tran Minh Hai, Yasuto Matsuda, Taisaku Suzuki, Tomohisa Wada, "An OFDM Receiver with Frequency Domain Diversity Combined Impulsive Noise Canceller for Underwater Network," The Scientific World Journal (Communication), Article ID 841750, Hindawi Publishing Corporation July 2015.
- [7] Taisaku Suzuki, Hai Minh Tran, and Tomotaka Wada. "An underwater acoustic OFDM communication system with shrimp (impulsive) noise cancelling," Computing, Management and Telecommunications (ComManTel), 2014 International Conference on. IEEE, 2014.