

On Improvement of the ICI Canceller for OFDM Mobile DTV Receiver

Hai Minh TRAN[†] Tomohisa WADA[‡]

[†] Graduate School of Engineering and Science

[‡] Department of Information Engineering

[†] [‡] University of the Ryukyus, 1 Senbaru, Nishihara, Okinawa, 903-0213 Japan

E-mail: [†] haitran@lsi.ie.u-ryukyu.ac.jp, [‡] wada@ie.u-ryukyu.ac.jp

Abstract In mobile environment, the performance of OFDM mobile receivers is degraded severely because of Inter-Carrier-Interference (ICI) caused by Doppler Spread. Therefore, ICI canceller is an important task for the OFDM mobile receivers. [1] and [2] proposed an efficient method to reduce ICI. The main idea of this method is to linearly approximate time varying channel within one OFDM symbol. Then a large ICI matrix equation is given. However, in [1], [2], the estimated values of the channel transfer function—the diagonal of the ICI matrix is corrupted by ICI. Consequently, the equalized signal still is distorted. In this paper, we proposed an iterative method to improve performance of the original method. We implemented Jacobi iteration method with low complexity to solve the large ICI matrix equation. Next, at second iteration of Jacobi method, we improve the diagonal by removing ICI power from pilot symbols and re-estimating the channel transfer function. Simulation results for ISDB-T mode 3 demonstrated that our method could double performance of the original method under TU-6 channel and Doppler Spread. The improvement is better for two paths and one path Doppler channel.

Keyword Orthogonal frequency-division multiplexing (OFDM), Jacobi Iteration, Inter-Carrier Interference (ICI).

1. Introduction

OFDM utilized a large number of orthogonal subcarrier to achieve high-spectral efficiency. The long duration symbol and guard interval protect useful part of OFDM symbols from inter-symbol-interference (ISI). Guard interval (GI) is implemented by cyclic prefix (CP). This scheme keeps OFDM symbols smoothly in time domain, and reduces out of band power of OFDM. Moreover, cyclic prefix keeps convolution of channel and OFDM symbol is circular convolution. However, in mobile environment, GI or CP could not avoid Doppler-effect. Doppler-effect spreads energy of one subcarrier to many other subcarriers. This is called ICI. On other word, in time-varying channel, the orthogonality among subcarriers is lost. Thus performance is degraded severely.

Many researches are conducted to deal with ICI caused by Doppler. In [1] and [2], an efficient approach is to linearly approximate time-varying channel within one OFDM symbol. Then we should solve a large ICI matrix equation. In [3], a method is proposed to solve the large ICI matrix equation. As most ICI power concentrated near the diagonal of ICI matrix, [3] considered D lines that are closest to the diagonal. Instead finding invert of $N \times N$

matrix, [3] find invert of N matrix of order $(2D + 1) \times (2D + 1)$. This still requires heavy computation.

As pilot symbols are suffered ICI, the estimated values of the diagonal also is corrupted by ICI. In addition, the diagonal is the most important element. Therefore, performance of [1], [2] is limited, even we solve the full ICI matrix equation exactly. In this paper, we applied Jacobi iteration method to solve the large ICI equation, so we don't need calculate any invert matrix. The simulation result shown that performance of Jacobi iteration at first iteration is the same as [3]. It is noted that Jacobi iteration method also is considered in [4]. However, in our method, we improve the diagonal of ICI matrix at second iteration of Jacobi method. By using output of the first iteration, we remove ICI from pilot symbols. Then, we re-estimate the diagonal of ICI matrix. As the diagonal is reliable, our method achieved a good improvement at second iteration.

The rest of paper is organized as follows: Section 2 reviews ICI reduction by linear approximation of time varying channel. Section 3.1 shows Jacobi iteration method for the large ICI matrix equation. Section 3.2 introduces two iterations method with improved the diagonal of the ICI matrix. Simulation result is shown in

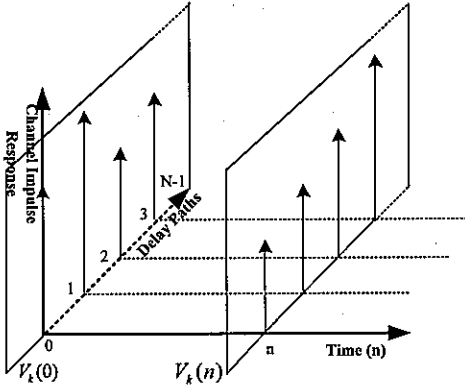

Fig. 1. $V_k(n)$ In Time Domain

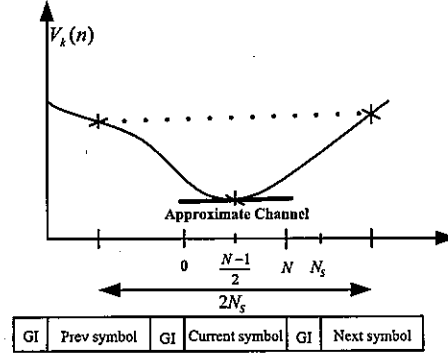

Fig. 2. Approximation of $V_k(n)$

section 4. Finally, conclusion is presented in section 5.

2. Review of ICI reduction by linear approximation of time varying channel

2.1. A linear approximation of time varying channel

As in [1], the received signal in frequency domain can be written as follows:

$$Y(k) = X(k)H_{k,k} + \sum_{l=0, l \neq k}^{N-1} X(l)H_{k,l} + W(k) \quad (1)$$

$$H_{k,l} = \frac{1}{N} \sum_{n=0}^{N-1} \sum_{m=0}^{N-1} h(m,n) e^{-j\frac{2\pi m}{N}n} e^{-j\frac{2\pi n}{N}(k-l)} \quad (2)$$

$X(k)$ and $Y(k)$ is transmitted and received signal respectively. l , and k are subcarrier indexes. $h(m,n)$ is channel impulse response of path m at instant time n . N is number of subcarrier. W denotes random noise.

$$V_k(n) = \sum_{m=0}^{N-1} h_m(n) e^{-j\frac{2\pi}{N}lm} \quad (3)$$

By using two first terms of Taylor series for $V_k(n)$ at $\frac{N-1}{2}$ position.

$$V_k(n) \approx \bar{V}_k + \left(n - \frac{N-1}{2}\right) \bar{V}'_k \quad (4)$$

The first central difference at $\left(\frac{N-1}{2}\right)$ is approximated as

$$\bar{V}'_k \approx \frac{\bar{V}_k^{(next)} - \bar{V}_k^{(pre)}}{2N_s} \quad (5)$$

It is noted that error of the first central difference is

$(O(h^2))$, while the error of the first backward or forward difference is $(O(h))$ [5]. Therefore, \bar{V}'_k is approximated by the first central difference. From Eq. (1), (4), and (6) we have the ICI equation:

$$Y(k) = X(k)H_{k,k} + \sum_{l=0, l \neq k}^{N-1} X(l)\bar{V}'_k \Phi_{\Delta_l} + W(k), \quad \Delta_l = l - k \quad (6)$$

$$\Phi_{\Delta_l} = \frac{1}{N} \sum_{n=0}^{N-1} \left(n - \frac{N-1}{2}\right) e^{-j\frac{2\pi n}{N}(k-l)} = \frac{1}{e^{j\frac{2\pi}{N}\Delta_l} - 1}, \quad l \neq k \quad (7)$$

2.2. The large ICI matrix equation

From Eq. (8), the received signal can be represented by matrix form as follows:

$$[Y] = [H][X] + [W] \quad (8)$$

$$[X] = [H]^{-1}[Y] - [H]^{-1}[W] \quad (9)$$

It is noted that, for simplification, we assumed $W = 0$. In order to recover the transmitter signal, we should solve a very lager matrix equation. In ISDB-T mode 3, as number of subcarrier is $N = 8192$, finding inverse of $[H]_{8192 \times 8192}$ is a heavy task. Therefore, it is necessary to reduce complexity of Eq. (10).

In order to solve the larger matrix equation, we investigate structure of matrix $[H]$. Firstly we look into ICI power distribution. Absolute value of Φ_{Δ_l} indicates ICI power from subcarrier l^{th} to subcarrier k^{th} , $\Delta_l = l - k$ is distance between l^{th} and k^{th} subcarrier.

$$\begin{bmatrix} Y_0 \\ Y_1 \\ Y_2 \\ Y_3 \\ \dots \\ Y_{N-1} \end{bmatrix} = \begin{bmatrix} \bar{V}_0 & \phi_1 \bar{V}'_1 & \phi_2 \bar{V}'_2 & \dots & \phi_{N-1} \bar{V}'_{N-1} \\ \phi_{-1} \bar{V}'_0 & \bar{V}_1 & \phi_1 \bar{V}'_2 & \dots & \phi_{N-2} \bar{V}'_{N-1} \\ \phi_{-2} \bar{V}'_0 & \phi_{-1} \bar{V}'_1 & \bar{V}_2 & \dots & \phi_{N-1} \bar{V}'_{N-1} \\ \phi_{-3} \bar{V}'_0 & \phi_{-2} \bar{V}'_1 & \phi_{-1} \bar{V}'_2 & \dots & \dots \\ \dots & \dots & \dots & \dots & \dots \\ \dots & \dots & \dots & \dots & \dots \\ \phi_{-N+1} \bar{V}'_0 & \phi_{-N+2} \bar{V}'_1 & \phi_{-N+1} \bar{V}'_2 & \dots & \dots \end{bmatrix} \times \begin{bmatrix} X_0 \\ X_1 \\ X_2 \\ X_3 \\ \dots \\ X_{N-1} \end{bmatrix} + \begin{bmatrix} W_0 \\ W_1 \\ W_2 \\ W_3 \\ \dots \\ W_{N-1} \end{bmatrix} \quad (10)$$

$$\Phi_{\Delta_l} = \frac{1}{e^{j\frac{2\pi}{N}\Delta_l} - 1} = \frac{1}{2e^{j\frac{\pi\Delta_l}{N}} \sin\left(\frac{\pi\Delta_l}{N}\right)} \quad (11)$$

$$|\Phi_{\Delta_l}| = \frac{1}{\left|2 \sin\left(\frac{\pi\Delta_l}{N}\right)\right|} = \begin{cases} \frac{0.5N}{\pi\Delta_l} & \text{if } \Delta_l \rightarrow 0 \\ \frac{0.5N}{\pi(N + \Delta_l)} & \text{if } \Delta_l \rightarrow -N + 1 \end{cases} \quad (12)$$

$\Delta_l \rightarrow 0$ means that the subcarriers that are near l^{th} subcarrier causes a big ICI power on l^{th} subcarrier. $\Delta_l \rightarrow -N + 1$ means the subcarriers that are far l^{th} subcarrier may generate a big ICI power on l^{th} . For example, Fig.1 shows ICI power from $(N-1)$ subcarrier to 1^{st} subcarrier. In matrix form, ICI power concentrated on the elements that near the diagonal and the elements that at low-left corner or upper-right corner of $[H]$ matrix.

Because ICI power concentrated on near diagonal of $[H]$ matrix, in paper [1], [3] researchers considered D elements that closest the diagonal and solve $(2D+1) \times (2D+1)$ matrix size equation instead for $N \times N$ matrix equation. For example, $D=1$, we have 3×3 matrix equation as

$$\begin{bmatrix} Y_0 \\ Y_1 \\ Y_2 \end{bmatrix} = \begin{bmatrix} \bar{V}_0 & \phi_1 \bar{V}'_1 & \phi_2 \bar{V}'_2 \\ \phi_{-1} \bar{V}'_0 & \bar{V}_1 & \phi_1 \bar{V}'_2 \\ \phi_{-2} \bar{V}'_0 & \phi_{-1} \bar{V}'_1 & \bar{V}_2 \end{bmatrix} \times \begin{bmatrix} X_0 \\ X_1 \\ X_2 \end{bmatrix} \quad (13)$$

By increasing D we can achieve more improvement, but the computational complexity also is increased. Even $D=1$ we should find N invert matrix size of $[3 \times 3]$. In next section, by using Jacobi iteration we do not need calculate inverse of any matrix, while performance is remaining.

3. Two iterations method with improved the diagonal of the ICI matrix

3.1. Jacobi iteration method for the large ICI matrix

In this section, we apply Jacobi iteration method for the large ICI matrix equation. The equation $[H][X] = [Y]$ can be re-written as

$$([P] + [T])[X] = [Y] \quad (14)$$

$$[P][X] = [Y] - [T][X] \quad (15)$$

In pure Jacobi iteration method, $[P]$ is diagonal of $[H]$ and $[T]$ is remained part of $[H]$. The approximate solution X_{k+1} is updated as:

$$[P][X_{k+1}] = [Y] - [T][X_k] \quad (16)$$

Because $[P]$ is diagonal matrix, it is easy to solve above equation. The initial value $X^{(0)}$ is calculated from 1taps equalizer. For example, k^{th} subcarrier is updated at 1^{st}

$$X_k^{(0)} = \frac{Y_k}{H_{k,k}} \quad (17)$$

$$X_k^{(1)} = \frac{Y_k - \sum_{l=0, l \neq k}^{N-1} X_l^{(0)} \phi_{l-k} \bar{V}'_l}{H_{k,k}} \quad (18)$$

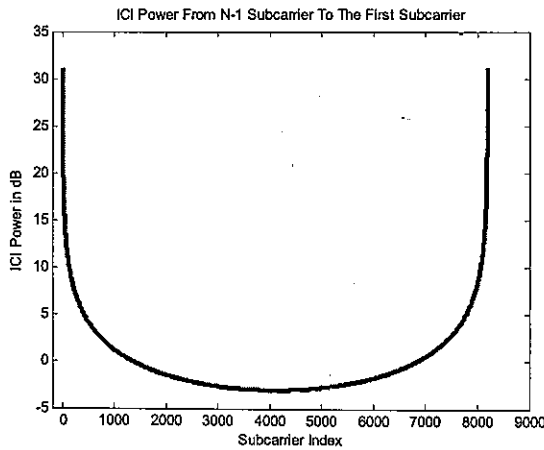

Fig. 3. ICI Power From Other Subcarriers to First Subcarrier

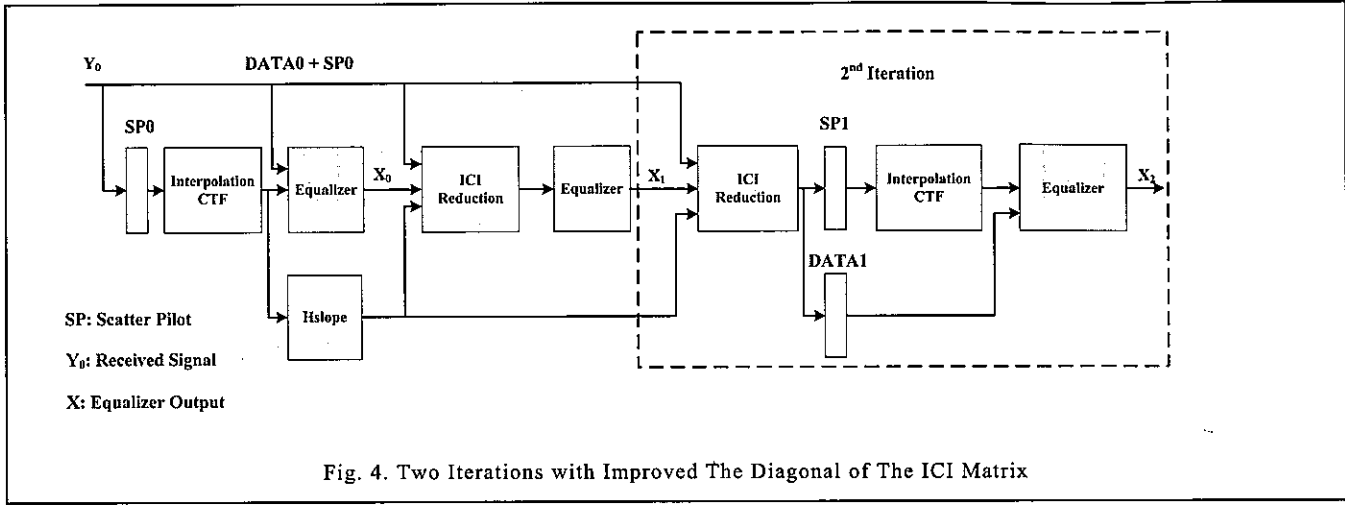

Fig. 4. Two Iterations with Improved The Diagonal of The ICI Matrix

At each iteration, error is

$$e_{k+1} = [X]_{k+1} - [X] = (I - [P^{-1}][H])e_k = [M]e_k \quad (19)$$

$$e_{k+1} = [M]^k e_1 \leq |\lambda_M|^k e_1, \quad (20)$$

λ_M is the biggest engine value of $[M]$. In this case, as the diagonal is dominated, Jacobi iteration method is effective. For more detail about Jacobi iteration, please refer to [4], [5].

Since most ICI power concentrated near the diagonal, we can reduce size of T to get the low complexity. We form T by 30 elements that are nearest the diagonal. Subcarrier k^{th} is updated at first and second iteration as follows:

$$X_k^{(1)} = \frac{Y_k - \sum_{\Delta_k=-15, \#0}^{15} X_{\Delta_k+k}^{(0)} \Phi_{\Delta_k} \overline{V'_{\Delta_k+k}}}{H_{k,k}} \quad (21)$$

$$X_k^{(2)} = \frac{Y_k - \sum_{\Delta_k=-15, \#0}^{15} X_{\Delta_k+k}^{(1)} \Phi_{\Delta_k} \overline{V'_{\Delta_k+k}}}{H_{k,k}} \quad (22)$$

Φ_{Δ_k} , $\Delta_k = -15, -14, \dots, 15$ is fixed coefficient as Eq. (11). We can implement iteration equation by a FIR filter 31 taps Φ_{Δ_k} .

3.2. Two iterations method with improved the diagonal of ICI matrix

As section 1 and Eq. (10), the diagonal of $[H]$ is $H_{k,k}$ as

$$H_{k,k} = \frac{1}{N} \sum_{n=0}^{N-1} V_k(n) = \bar{V}_k \quad (23)$$

\bar{V}_k is used for approximating the first central difference of $V_k(n)$

$$\bar{V}'_k \approx \frac{\bar{V}_k^{(next)} - \bar{V}_k^{(pre)}}{2N_s} \quad (24)$$

As Jacobi method in section 3.1, after 1st iteration, $X_k^{(1)}$ is found as

$$X_k^{(1)} = \frac{Y_k - \sum_{\Delta_k=-15, \#0}^{15} X_{\Delta_k+k}^{(0)} \Phi_{\Delta_k} \overline{V'_{\Delta_k+k}}}{H_{k,k}} \quad (25)$$

The term $\sum_{\Delta_k=-15, \#0}^{15} X_{\Delta_k+k}^{(0)} \Phi_{\Delta_k} \overline{V'_{\Delta_k+k}}$ is ICI power caused by 30 subcarriers. Therefore, after 1st iteration, ICI in $X_k^{(1)}$ is reduced significantly.

At second iteration, equalizer output is calculated as

$$X_k^{(2)} = \frac{Y_k - \sum_{\Delta_k=-15, \#0}^{15} X_{\Delta_k+k}^{(1)} \Phi_{\Delta_k} \overline{V'_{\Delta_k+k}}}{H_{k,k}} \quad (26)$$

$H_{k,k}$ is the same in 1st and 2nd iteration. It is noted that $H_{k,k}$ is estimated from pilot that is already corrupted by ICI. Consequently, $X_k^{(2)}$ still is distorted due to the corrupt $H_{k,k}$. In order to improve performance, we improve $H_{k,k}$ at 2nd iteration. Firstly, we remove ICI from pilot symbols by using output at 1st iteration as follows

$$X_m^{(new)} = Y_m - \sum_{\Delta_m=-15, \#0}^{15} X_{\Delta_m+m}^{(1)} \Phi_{\Delta_m} \overline{V'_{\Delta_m+m}} \quad (27)$$

m is pilot symbol index. Then, we utilized new pilots $X_m^{(new)}$ to re-estimate the channel transfer function $H_{k,k}$. Because ICI in $X_m^{(new)}$ is reduced significantly, the re-estimated $H_{k,k}^{(new)}$ is not influenced by ICI. Finally, the

recover signal at second iteration is updated as

$$X_k^{(2)} = \frac{Y_k - \sum_{\Delta_k=-15, \neq 0}^{15} X_{\Delta_k+k}^{(1)} \Phi_{\Delta_k} \sqrt{V_{\Delta_k+k}}}{H_{kk}^{(new)}} \quad (28)$$

The all above procedures are shown in Fig. 4.

4. Simulation result

In this section, we evaluate performance of the proposed method for ISDB-T mode 3. The parameters are shown in table I. Also we investigate performance of the original method with different value of D . Jacobi iteration method is compared with method in [3].

As section 1, [3] proposed a method to solve the large ICI matrix equation. Instead finding inverse of $N \times N$ matrix, [3] find inverse of N matrix order of $(2D + 1) \times (2D + 1)$. We set $D = 2, 7, 15$ and solve matrix order of $5 \times 5, 15 \times 15, 31 \times 31$ respectively. As shown in Fig. 5, under TU-6 channel condition, as D increases, the performance is improved. Because most ICI energy concentrated near the diagonal, improvement by increasing $D = 2$ to $D = 7$ or 15 is small.

Next, we compared Jacobi iteration method and method in [3] with $D = 15$. In Fig 6, pure Jacobi 1st iteration is Jacobi iteration at 1st iteration, and $T = H - D$. Modified Jacobi 31 taps used 30 lines that closest the diagonal of ICI matrix for T . In Fig. 6, under TU-6 channel, the modified Jacobi with 31 taps achieved a performance as $D = 15$ or pure Jacobi iteration. Therefore, we choose the modified 31 taps to implement the proposed method.

We evaluated performance of the two iteration with improved the diagonal method under three channel conditions. The parameters for three channel conditions are shown in Table II, III, and IV.

In Fig. 7, under TU-6 channel, our method doubles performance of the original method. Fig. 7, 8, 9 also shown that improvement of normal Jacobi method is very small at 2nd iteration. This is explained in Section 3.2.

Our method achieved more improvement for two paths and one path Doppler channel. At 2nd iteration, by reducing ICI effect in pilot symbols the diagonal is improved. However the residual ICI in pilot symbols still degrade reliability of the diagonal. As number of paths channel decreases, the residual ICI becomes smaller and the diagonal suffer less effect of the ICI residual. Therefore, our method got more improvement for one and two paths channel.

TABLE I. ISDB-T MODE 3 PARAMETERS

Parameters	Values
FFT size	8192
Number of sub-carrier	5617
Carrier interval	992.06(Hz)
Effective Sym. Duration	1008 μ s
Guard interval	126 μ s
Modulation	64QAM

TABLE II. TU-6 CHANNEL

Tap number	Delay (μ s)	Power (dB)	Doppler Spread (Hz)
1	0.0	-3.0	[0 200]
2	0.2	0.0	[0 200]
3	0.5	-2.0	[0 200]
4	1.6	-6.0	[0 200]
5	2.3	-8.0	[0 200]
6	5.0	-10.0	[0 200]

TABLE III. TWO PATHS DOPPLER CHANNEL

Tap number	Delay (μ s)	Power (dB)	Doppler Spread (Hz)
1	0.0	0.0	[0 200]
2	12.3	-3.0	[0 200]

TABLE IV. ONE PATH DOPPLER CHANNEL

Tap number	Delay (μ s)	Power (dB)	Doppler Spread (Hz)
1	100	-3.0	[0 200]

5. Conclusion

In this paper, we achieved a good improvement by updating the diagonal of ICI matrix at second iteration. Also, we implemented Jacobi iteration with low complexity. The performance of our method is evaluated and compare with original method. As simulation result, our method doubled performance of original method for TU-6 channel. The improvement is better for two paths and one path Doppler channel

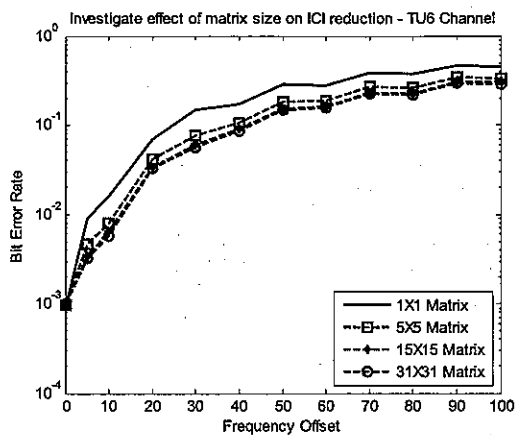

Fig. 5. The Original Method with different value of D under TU-6 Channel

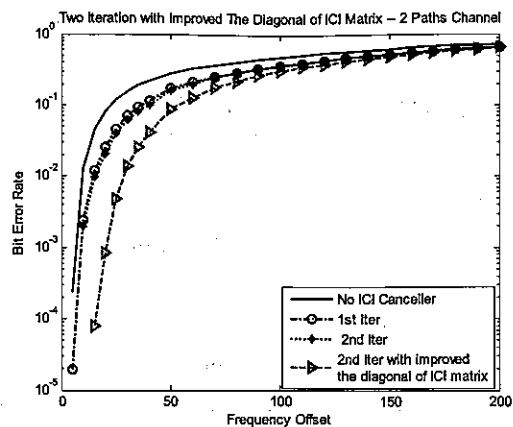

Fig. 8. The Proposed Method with 2 Paths Channel

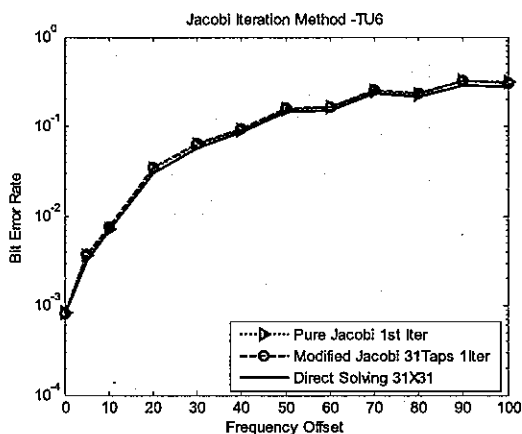

Fig. 6. Jacobi Iteration Method with TU-6 Channel

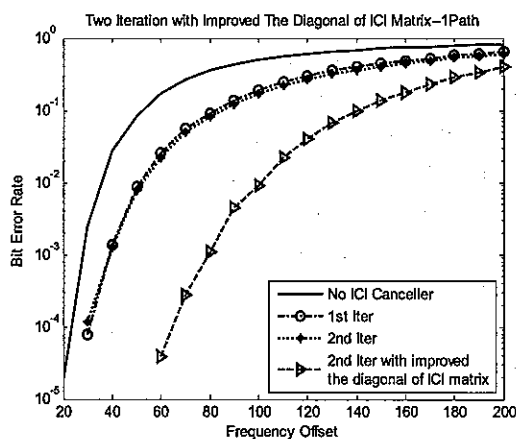

Fig. 9. The Proposed Method with One Paths Doppler Channel

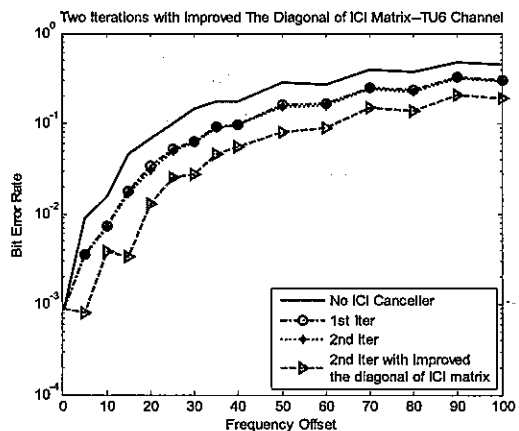

Fig. 7. The Proposed Method with TU-6 Channel

References

[1] Fischer, V. and Kurpiers, A. and Karsunke, D., "ICI reduction method for ofdm systems", *Hamburg: 8th International OFDM-Workshop*, pp. 1-5, 2003.

[2] Mostofi, Y. and Cox, D.C., "ICI mitigation for pilot-aided OFDM mobile systems", *IEEE Transactions on, IEEE*, vol. 4, no. 2, pp. 765-774, 2005.

[3] Jeon, W.G. and Chang, K.H. and Cho, Y.S., "An equalization technique for orthogonal frequency-division multiplexing systems in time-variant multipath channels", *IEEE Transactions on, IEEE*, vol. 47, no. 1, pp. 27-32, 1999.

[4] Molisch, A.F. and Toeltsch, M. and Vermani, S., "Iterative methods for cancellation of intercarrier interference in OFDM systems", *Vehicular Technology, IEEE Transactions on, IEEE*, vol. 56, no. 4, pp. 2158-2167, 2007

[5] Strang, G. and Massachusetts Institute of Technology, "Computational science and engineering", Wellesley-Cambridge Press Wellesley, MA, 2007.