

Field Programmable Gate Array

What is FPGA?

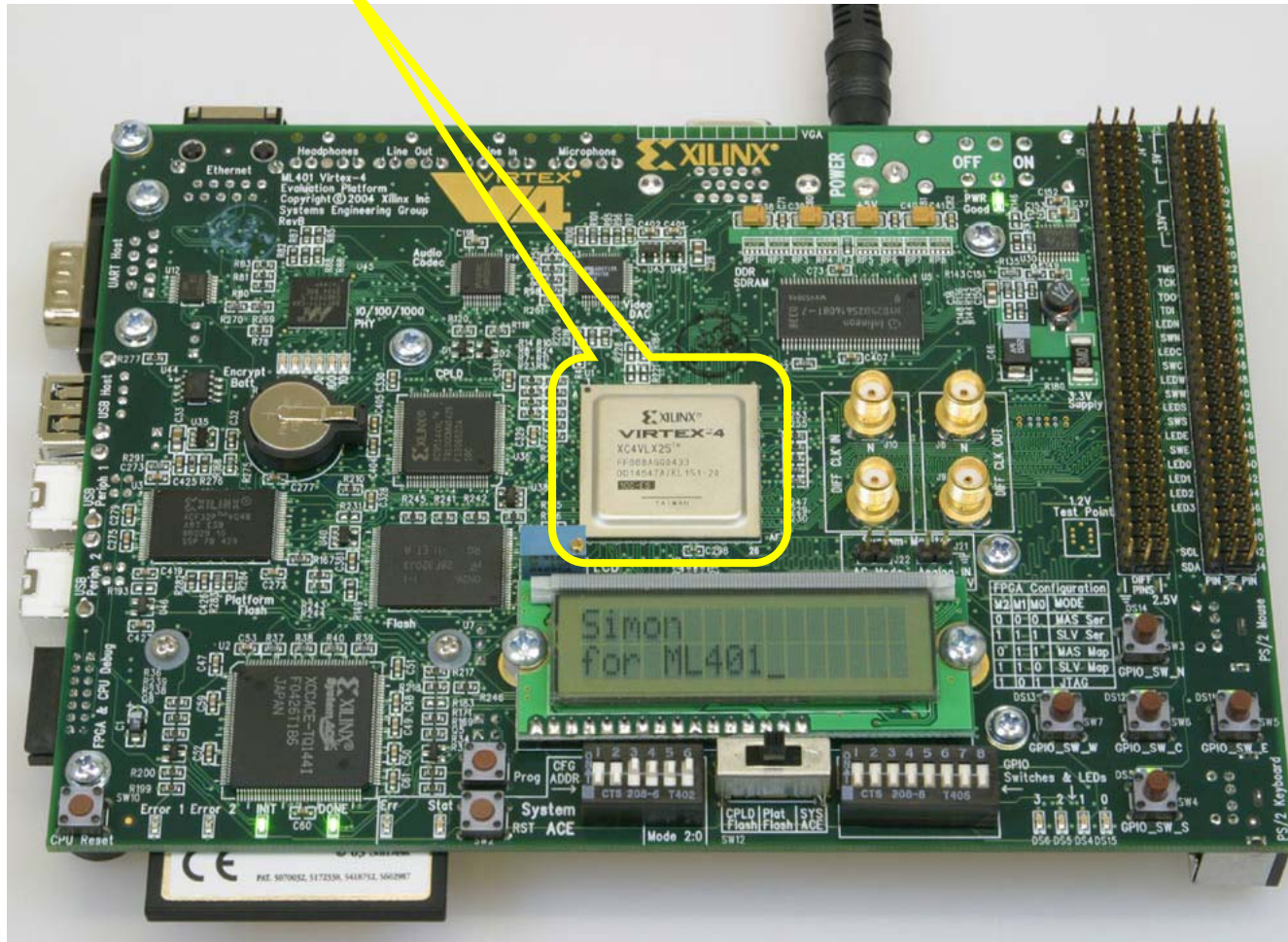



FPGA

- Programmable (= reconfigurable) Digital System
- Component
 - Basic components
 - Combinational logics
 - Flip Flops
 - Macro components
 - Multiplier (large combinational logic)
 - Random Access Memory (Large Density)
 - Read Only memory (Large Density)
 - CPU
 - Programmable Interconnection
 - Programmable Input/Output circuit
 - Programmable Clock Generator

What is Combinational Logic?

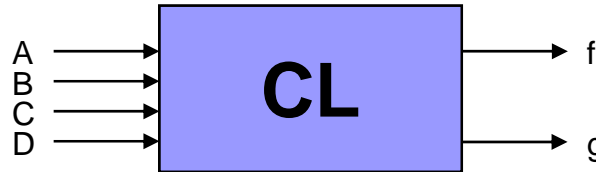

A, B, C, D, f, g are all binary signal.

- If output f, g are function of only inputs (A, B, C, D) then the circuit is combinational circuit.
- In another word, output signal is determined by only the combination of input signals.
 - $f = \text{func1}(A, B, C, D)$
 - $g = \text{func2}(A, B, C, D)$
- Combinational logic does NOT include memories such as Flip-Flops.
- Combinational logic can be constructed by just primitive gates such as NOT, NAND, NOR, etc. (But no feedback loop)

Combinational Logic realization - gates -

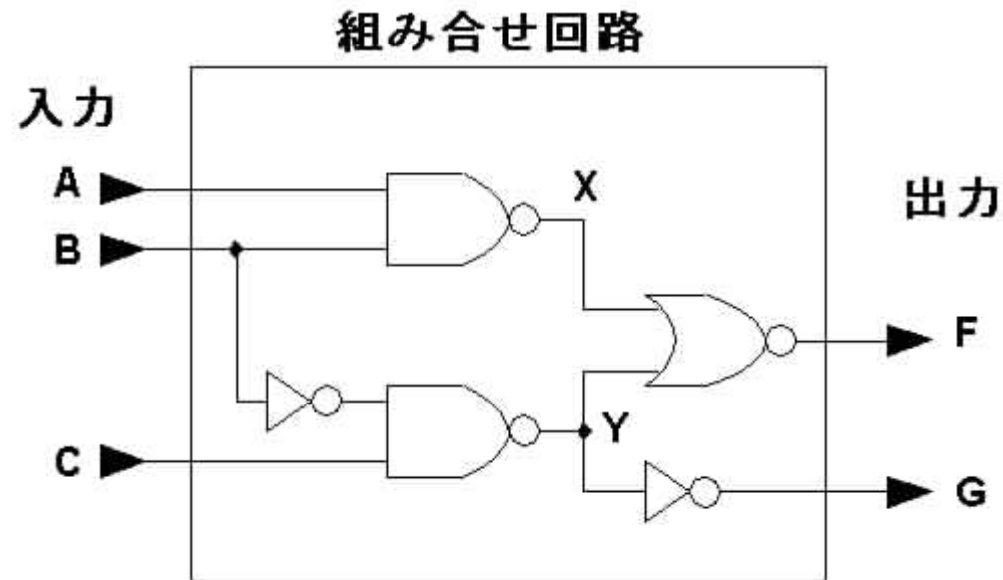

- There is no signal loop in the circuit.
- In combinational logic, signal loop is prohibited since the loop makes states (Memory).
- Function is not configurable.

Combinational Logic realization - Table -

TRUTH TABLE

A	B	C	f
0	0	0	0
0	0	1	0
0	1	0	0
0	1	1	0
1	0	0	0
1	0	1	0
1	1	0	1
1	1	1	1

- Function is configurable by storing the TABLE values.

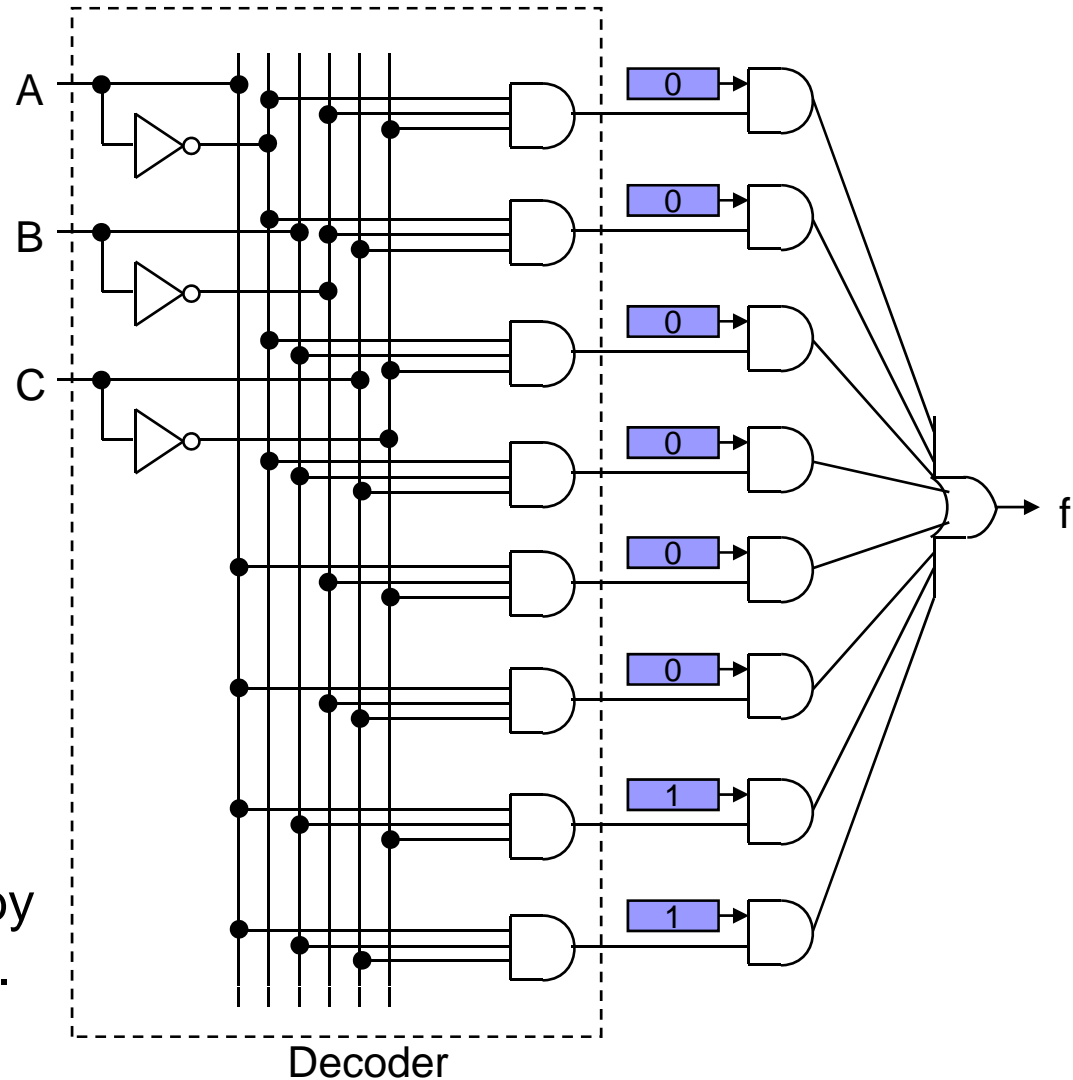

Clocked D LATCH

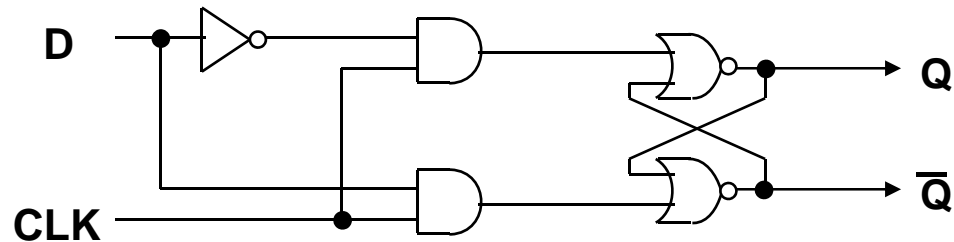

- 1 bit memory by NOR cross-loop
- When CLK=1, $Q = D$, $\bar{Q} = \text{not}(D)$
- When CLK=0, Q holds previous data.

When CLK='1'

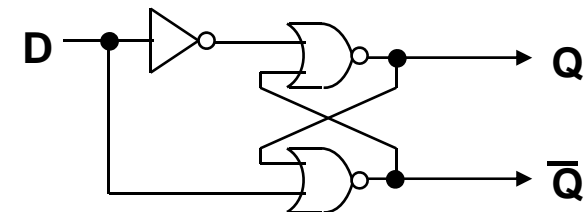

When CLK='0'

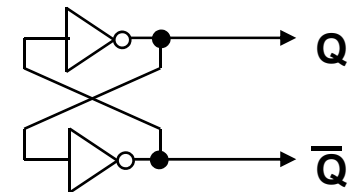

CIRCUIT SYMBOL:

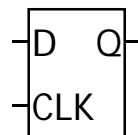

Master-Slave D Flip-Flop

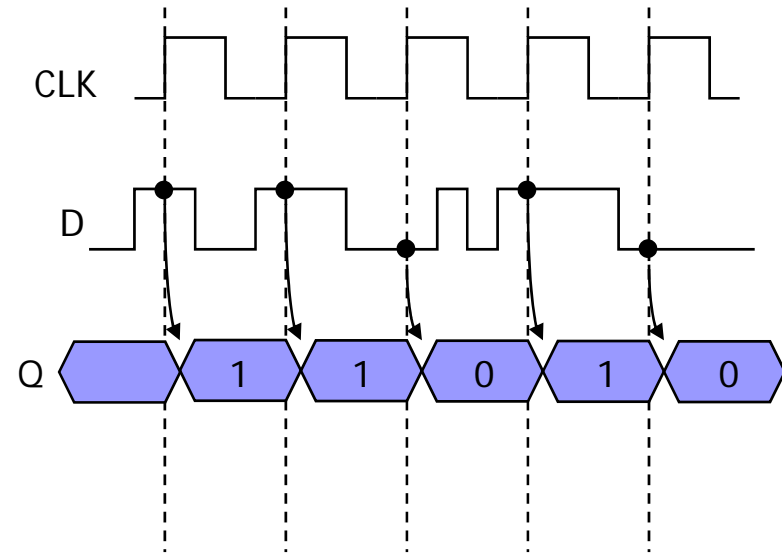
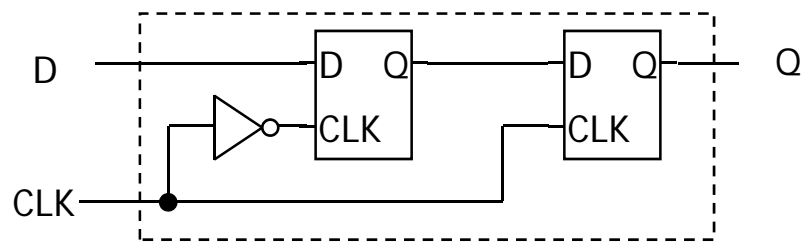

- 2 LATCHES in series
- Still work as 1 bit memory
- CLK edge Trigger Operation
- Most commonly used memory element in the state-of-the-art synchronous Digital Design.
- Q only changes CLK edge (once in one cycle).

CIRCUIT SYMBOL:

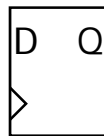

Digital System is just FF + CLs

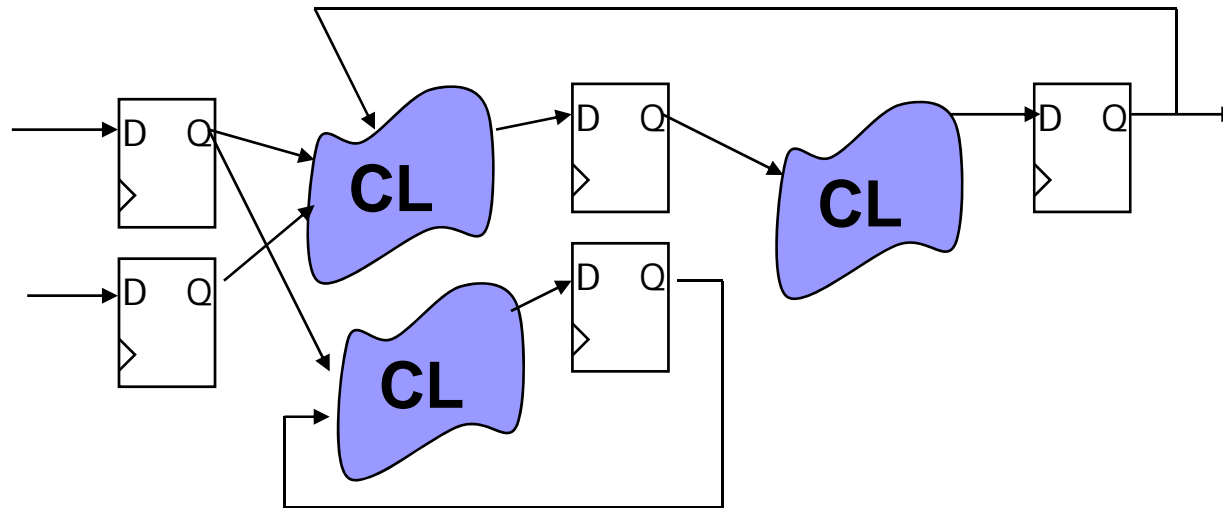

- FPGA supports such digital circuit with configurability.
- FPGA's basic element

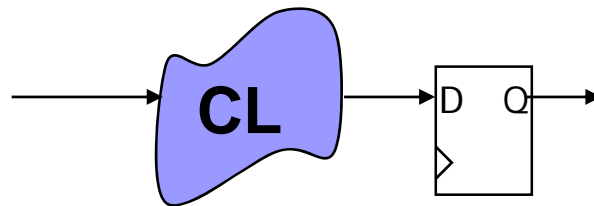

Example of Circuit Synthesis

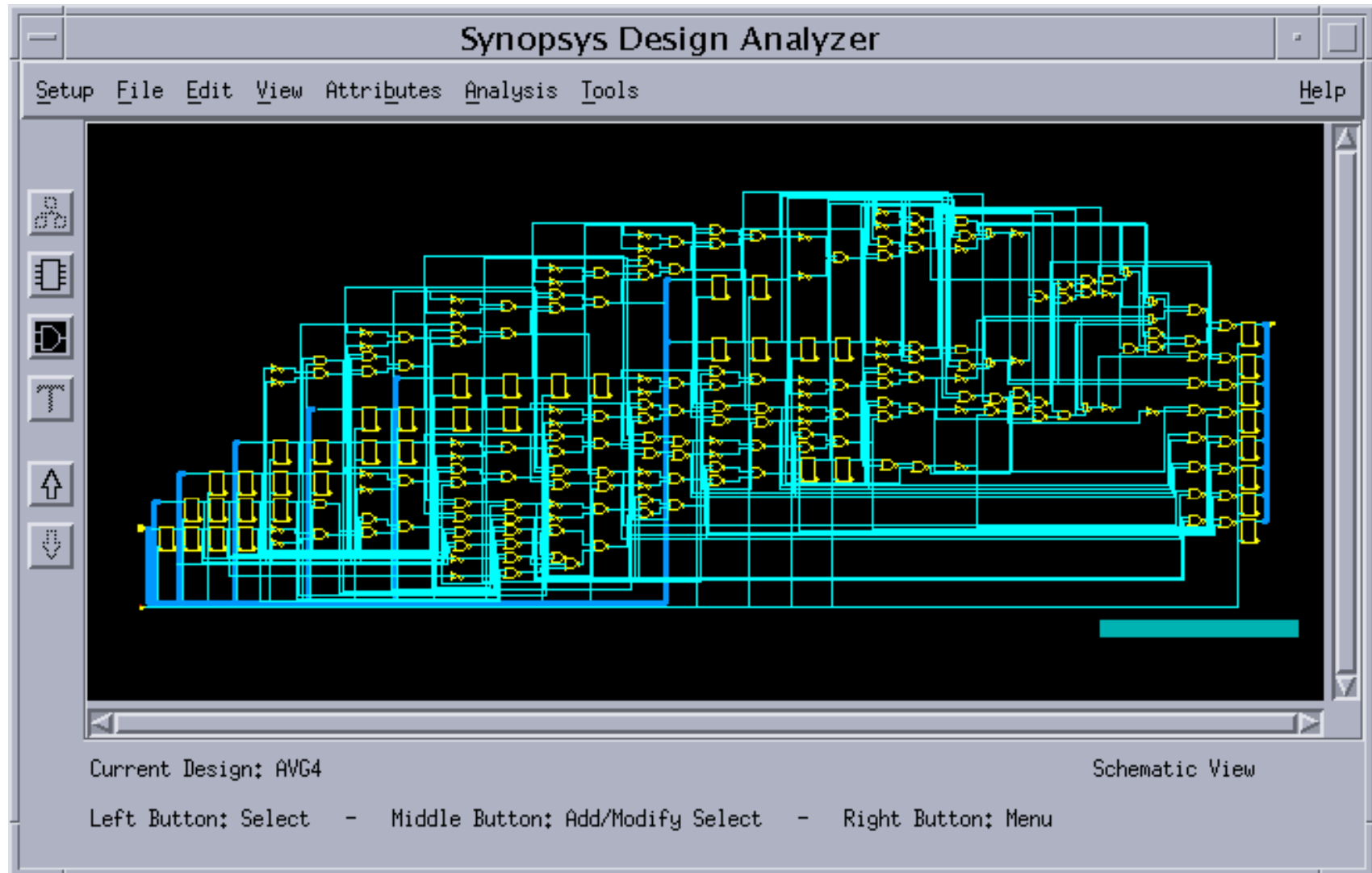



XILINX FPGA

- Field Programmable Gate Array

XILINX XC3000 Family I/O

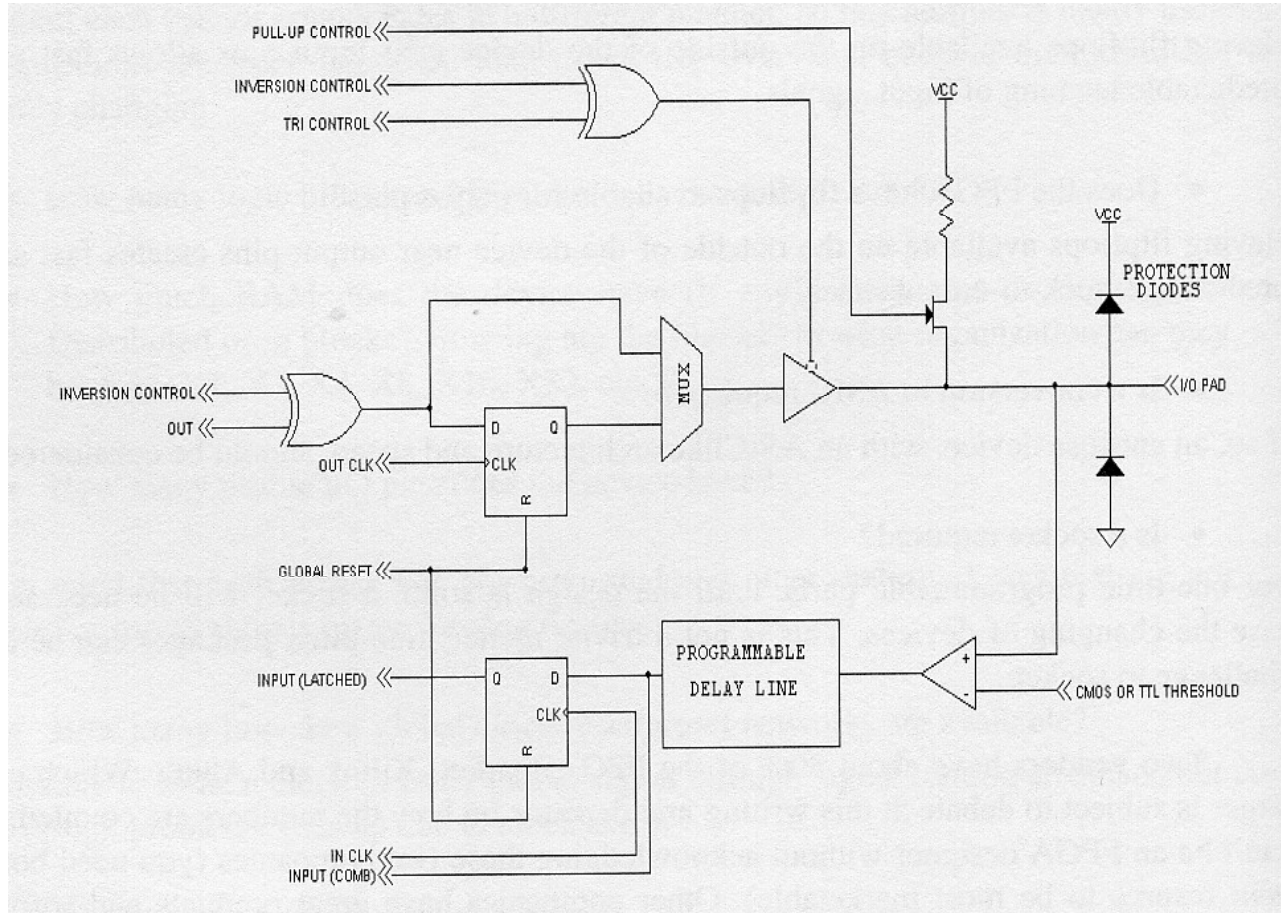

- Electronic Static Discharge Protection
- CMOS, TTL input
- Registered /Non Registered I/O

XILINX XC3000 Family CLB

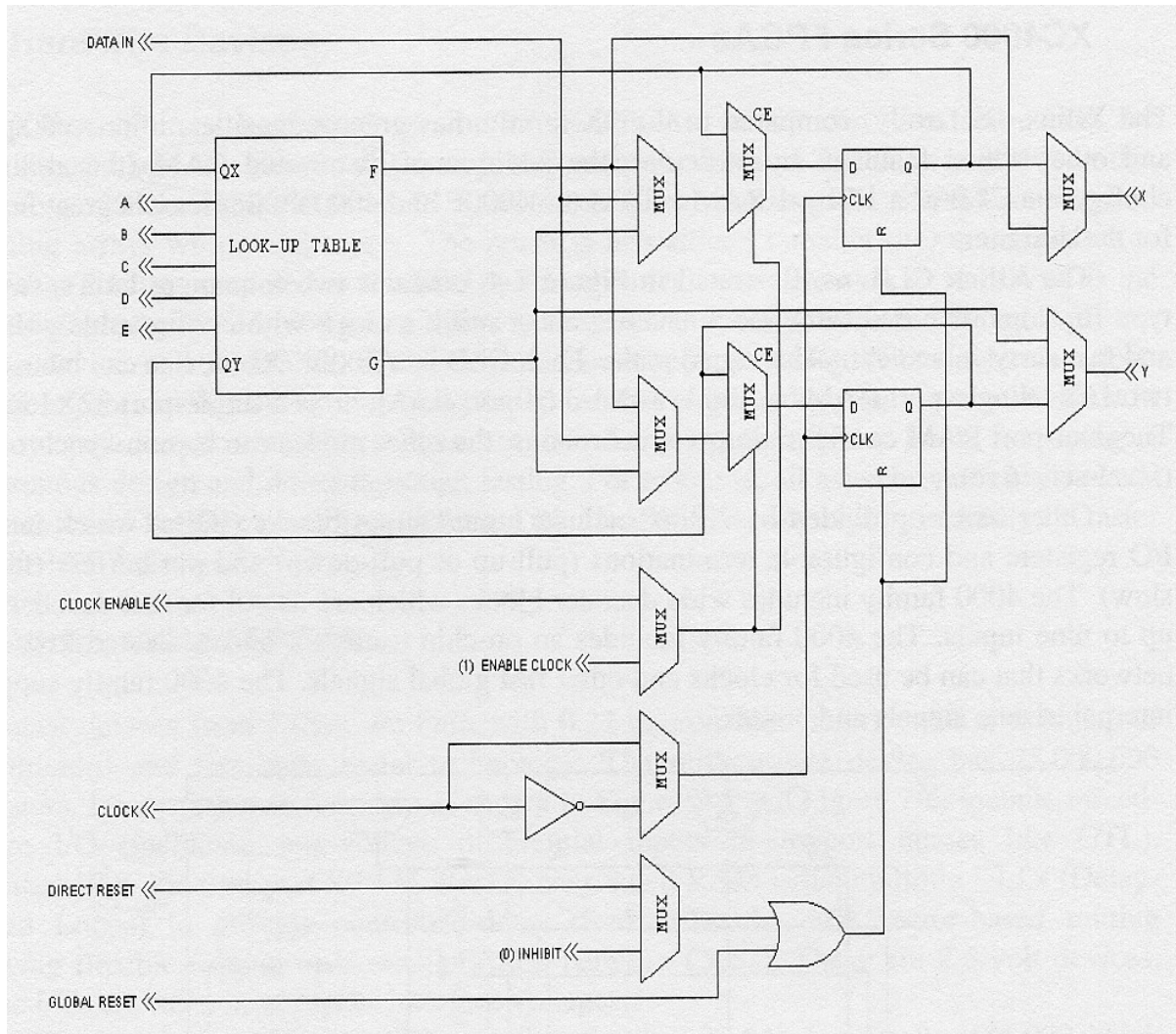

- CLB: Configurable Logic Block
- Look-up table for combinational logic
- D-Flip-Flops
- Look-up Table = RAM

XILINX XC4000 Family CLB

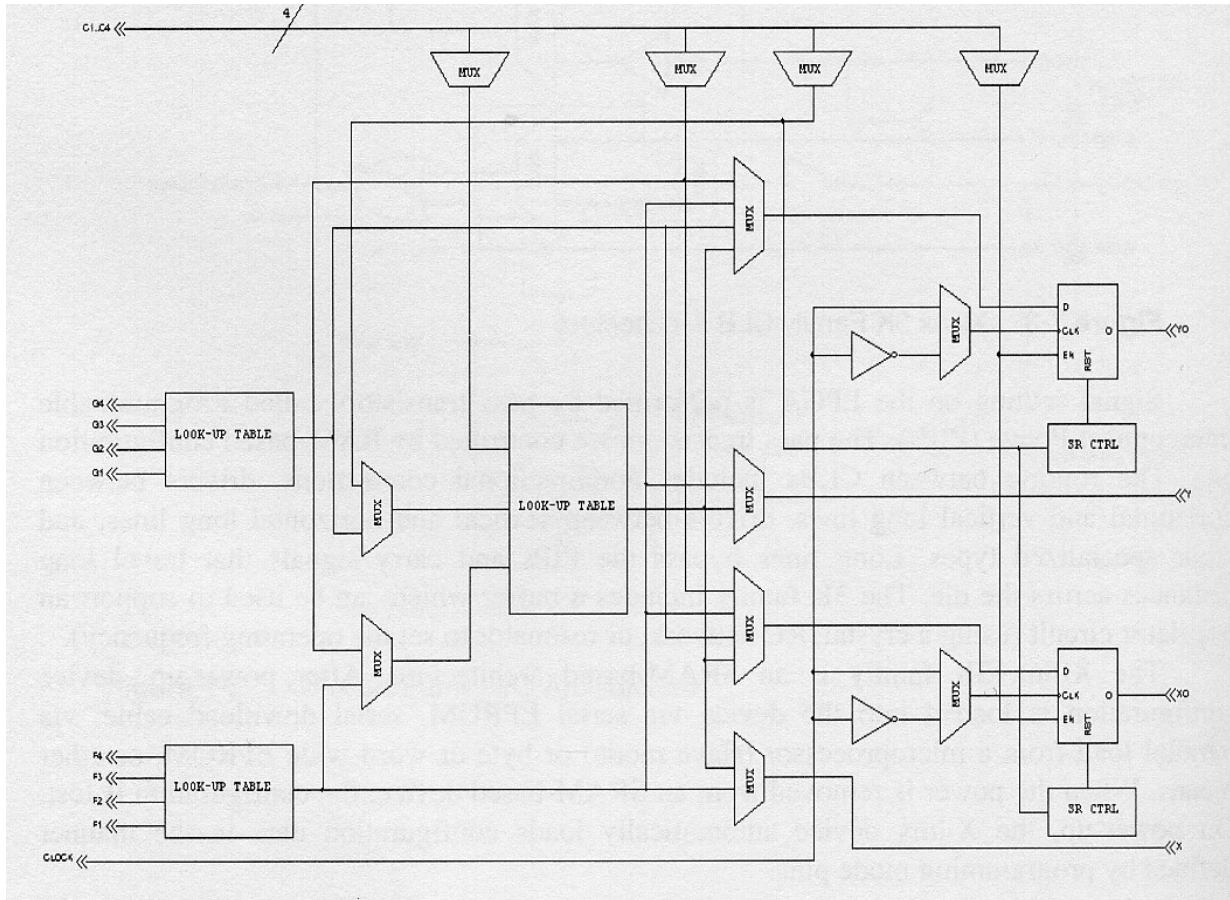

- Two Stage Look-up Table

XILINX VIRTEX FAMILY ARCHITECTURE

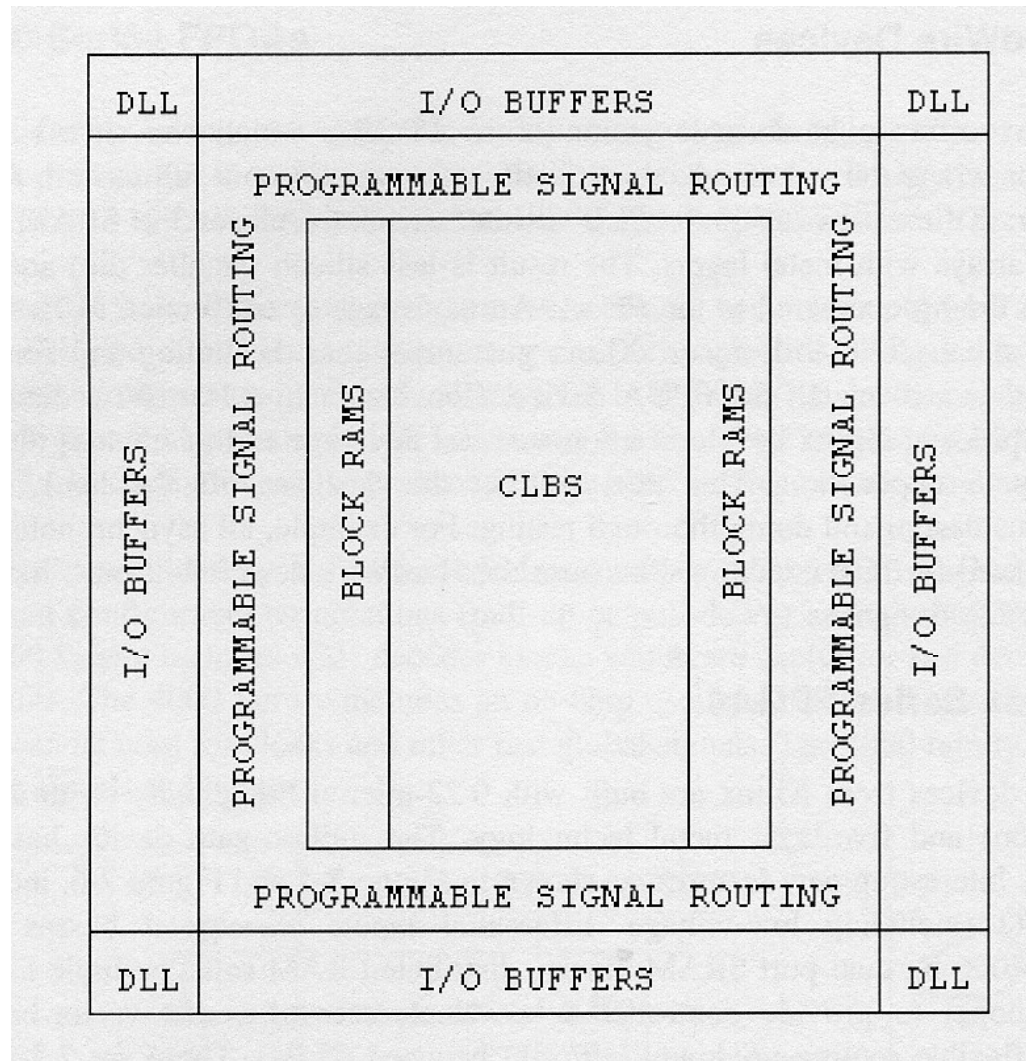

- CLB: Configurable Logic Block
- Many 4Kbit RAM BLOCK RAM
- DLL (Delay-Locked Loops) to provide controlled-delay clock networks
- Multiplier (18b x 18b) Macro also supported (not in figure)

XILINX VIRTEX FAMILY CLB

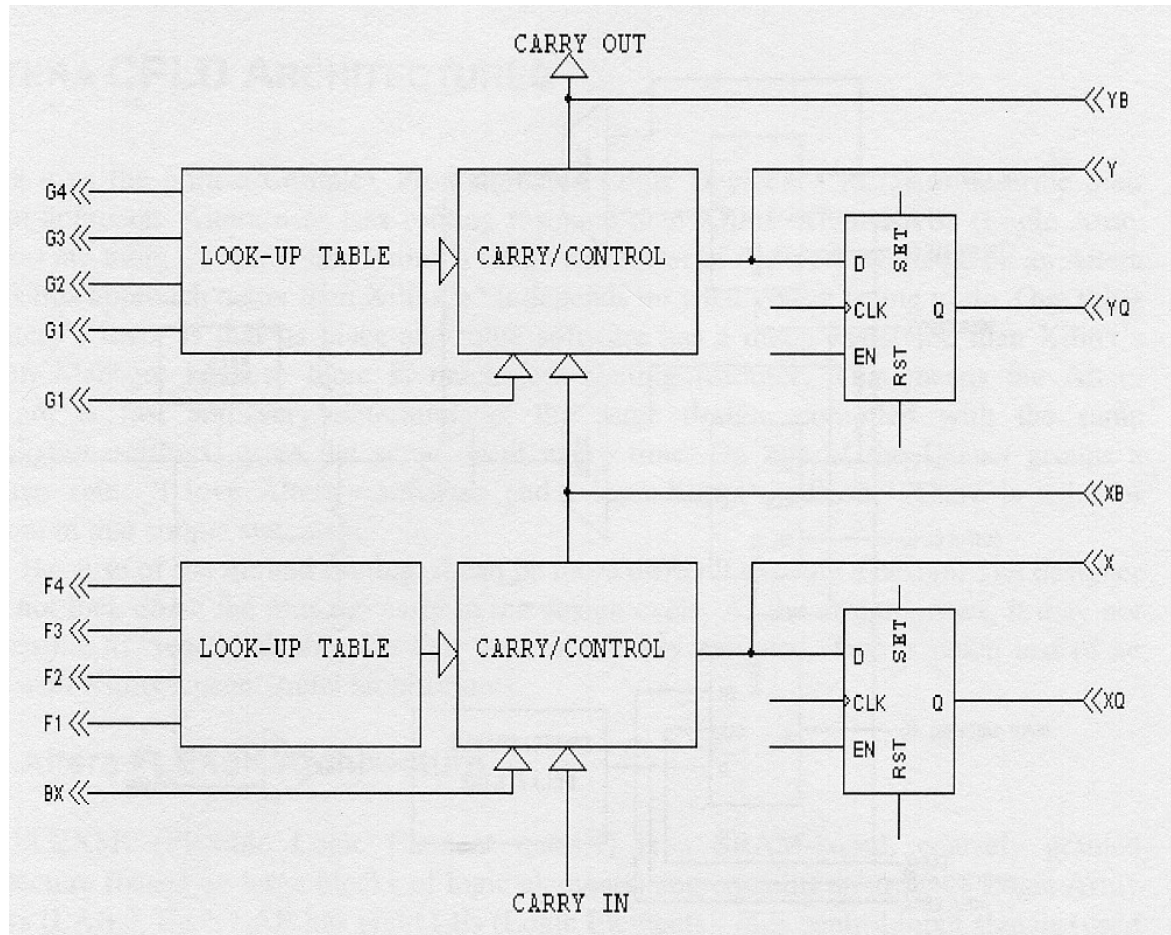

- CLB: Configurable Logic Block
- Many 4Kbit RAM BLOCK RAM
- DLL (Delay-Locked Loops) to provide controlled-delay clock networks

XILINX VIRTEX FAMILY I/O

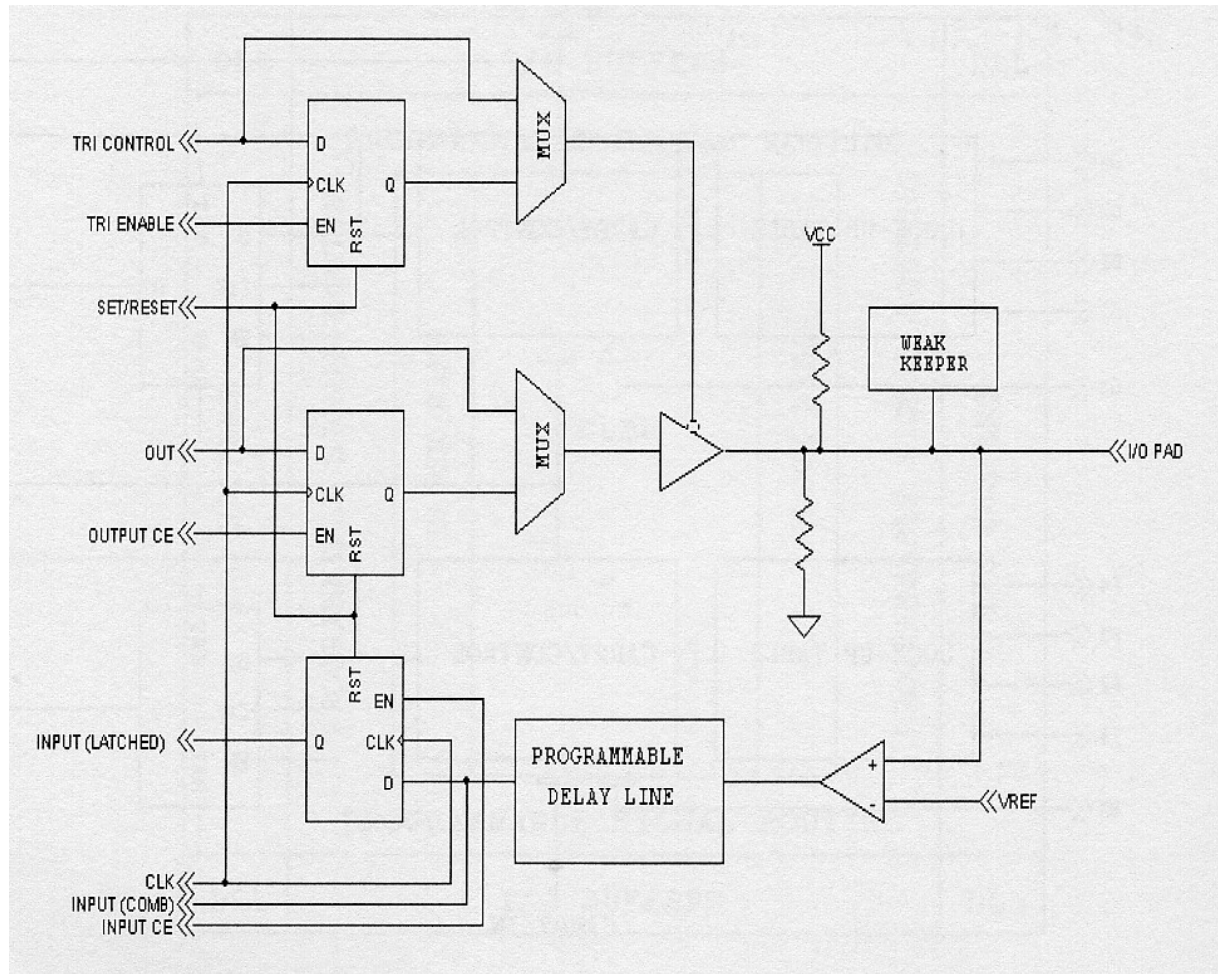

- Electronic Static Discharge Protection
- CMOS, TTL input
- Registered /Non Registered I/O



ALTERA CPLD

- Complex Programmable Logic Devices
- Altera uses less routing resource than Xilinx
- Altera's Logic Array Block (LAB) is more complex than Xilinx's CLBs. Then fewer LABs in on chip than Xilinx's CLBs.

ALTERA FLEX8000 ARCHITECTURE

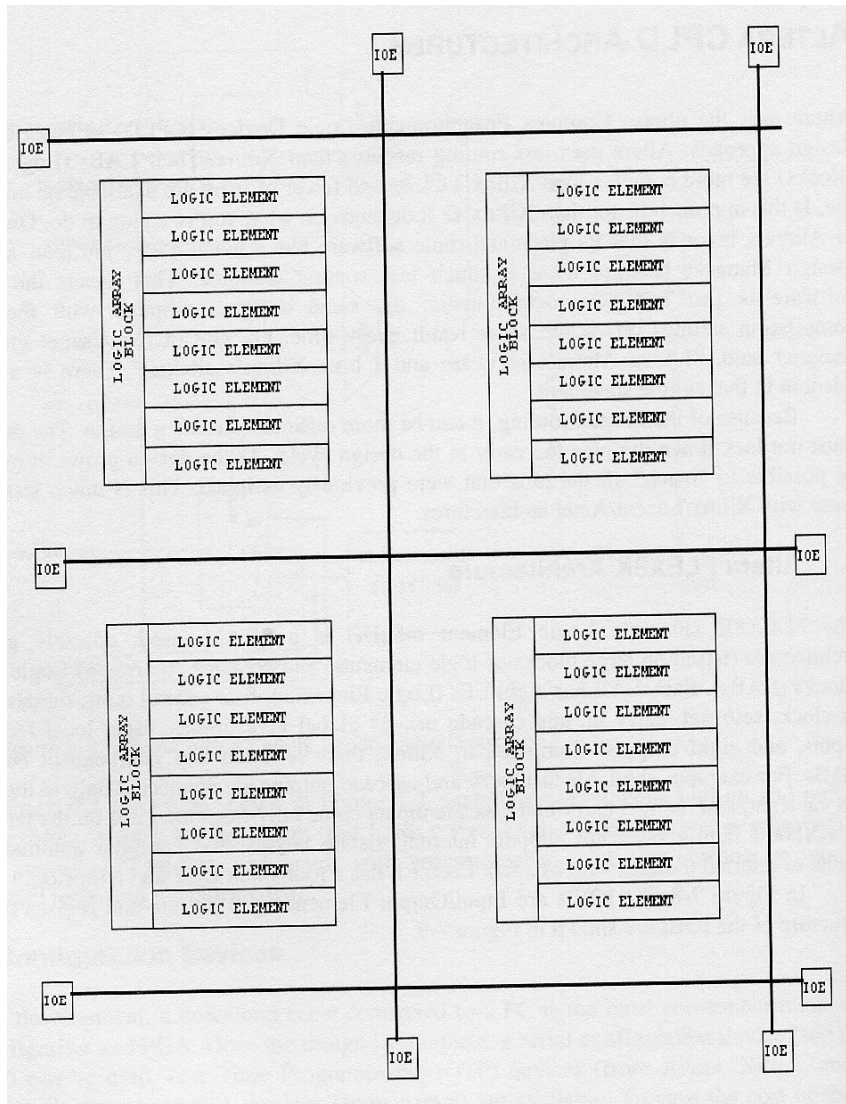

- Each LAB has eight LEs (Logic Elements) .

ALTERA FLEX8000 Logic Element (LE)

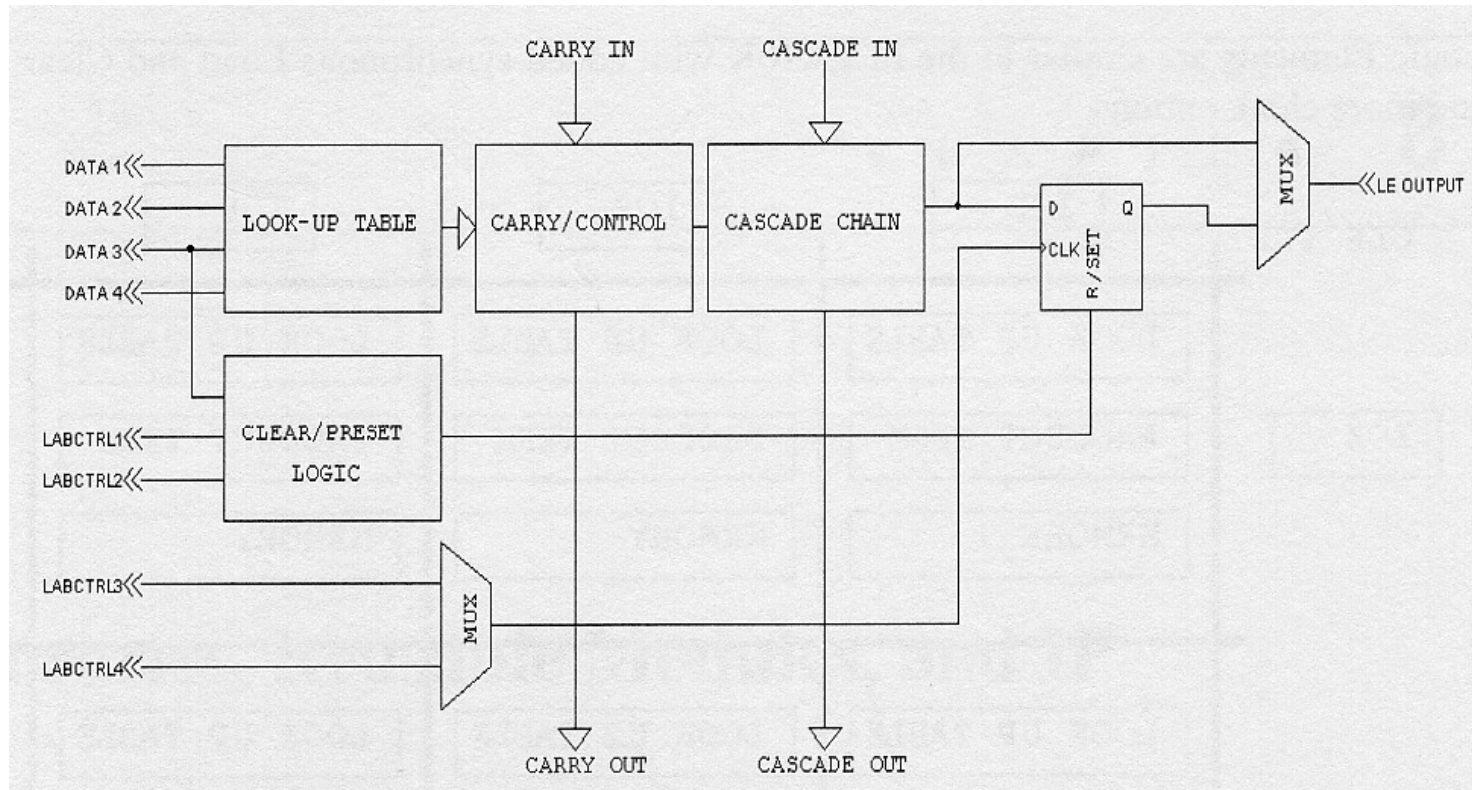

- CARRY, CASCADE signals

ALTERA APEX 20K ARCHITECTURE

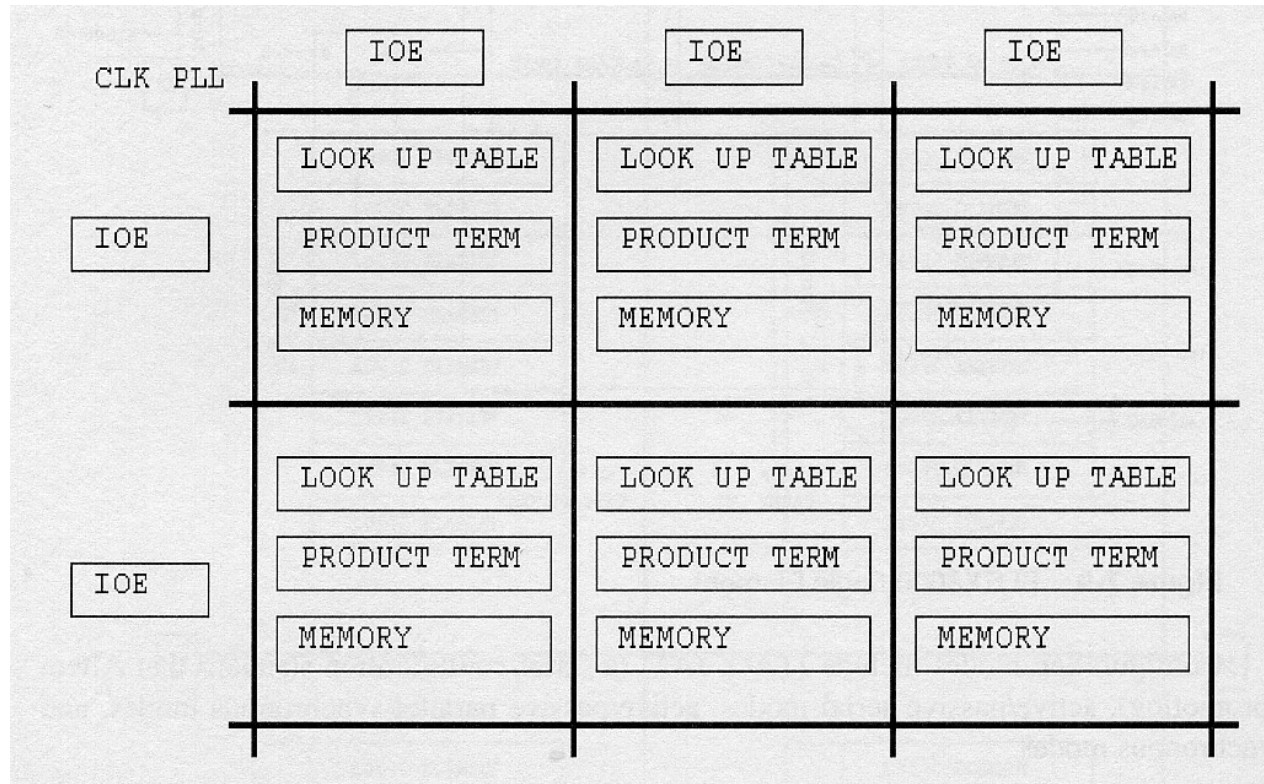

- MANY RAMs
- Large Number Input combinational logic such as Multiplier
- Phase Locked Loop for Advanced Clock generation

How to Design your Digital System using Hard-Macro Blocks

- White Blocks might be available (Hardware pre-designed Blocks)

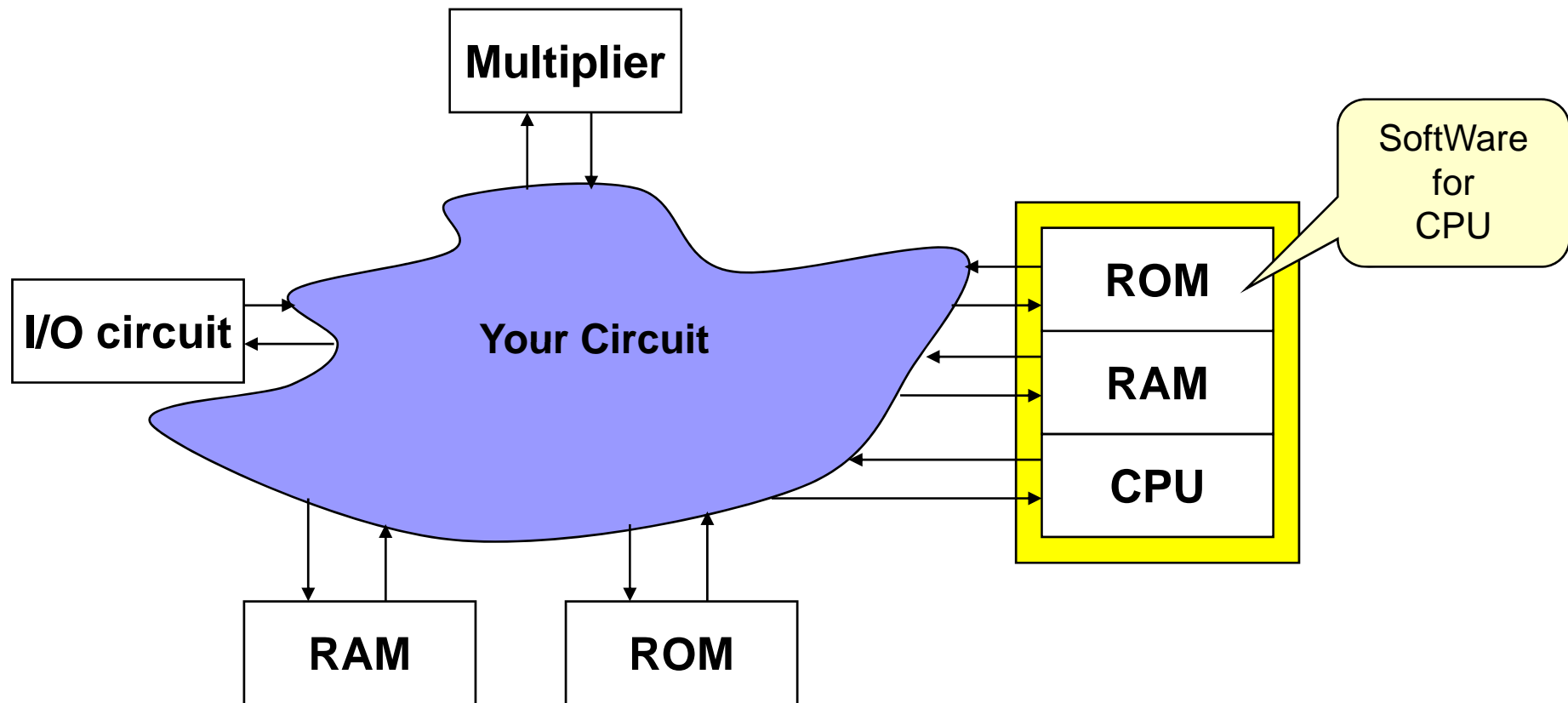



Hardware Description Languages (HDLs)

- HDL is a software programming language used to model the intended operation of a piece of hardware.
- Two level of modeling
 - Abstract behavior modeling
 - Hardware structure modeling:
Input to Circuit Synthesis
- Two kinds of Language
 - VHDL: Very High Speed Integrated Circuit hardware description language
 - Similar to Pascal Programming language
 - Verilog HDL:
 - Similar to C Programming language



HALF_ADDER example

VHDL

```
library IEEE;
use IEEE.std_logic_1164.all;

entity HALF_ADDER is
    port ( A, B : in std_logic;
          S, C : out std_logic );
end HALF_ADDER;

architecture STRUCTURE of HALF_ADDER is
begin
    S <= A xor B;
    C <= A and B;
end STRUCTURE;
```

Verilog HDL

```
module HALF_ADDER (
    A, B,
    S, C
);

input A, B;
output S, C;

assign S = A ^ B;
assign C = A & B;
endmodule
```

Moving Average Filter by VHDL

```
library IEEE;
use IEEE.STD_LOGIC_1164.all;
use IEEE.STD_LOGIC_ARITH.all;
```

```
entity AVG4 is
port(CLK : in std_logic;
      FMINPUT : in std_logic_vector(7 downto 0);
      AVGOOUT : out std_logic_vector(7 downto 0));
end AVG4;
```

architecture RTL of AVG4 is

```
signal FF1, FF2, FF3, FF4 : std_logic_vector(7 downto 0);
signal SUM : std_logic_vector(9 downto 0);
```

begin

-- SHIFT REGISTER

```
process(CLK) begin
if (CLK'event and CLK = '1') then
FF1 <= FMINPUT;
FF2 <= FF1;
FF3 <= FF2;
FF4 <= FF3;
end if;
end process;
```

-- SUM

```
SUM <= signed(FF1(7)&FF1(7)&FF1)+signed(FF2(7)&FF2(7)&FF2)
+signed(FF3(7)&FF3(7)&FF3)+signed(FF4(7)&FF4(7)&FF4);
```

-- DIVIDE BY 4 (SHIFT 2 bit), OUTPUT REGISTER

```
process(CLK) begin
if (CLK'event and CLK='1') then
AVGOOUT <= SUM(9 downto 2);
end if;
end process;
```

end RTL;

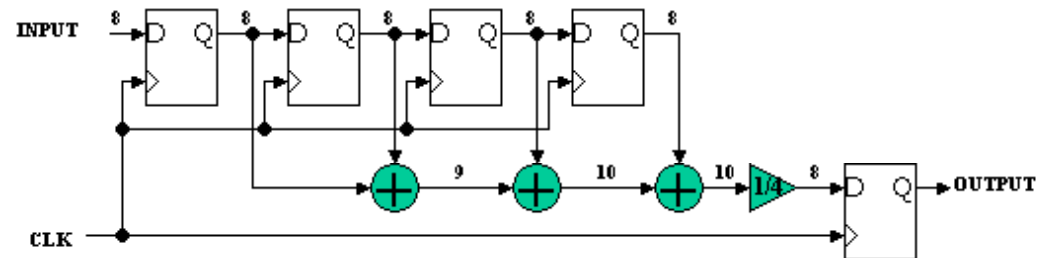

Simulated Waveform

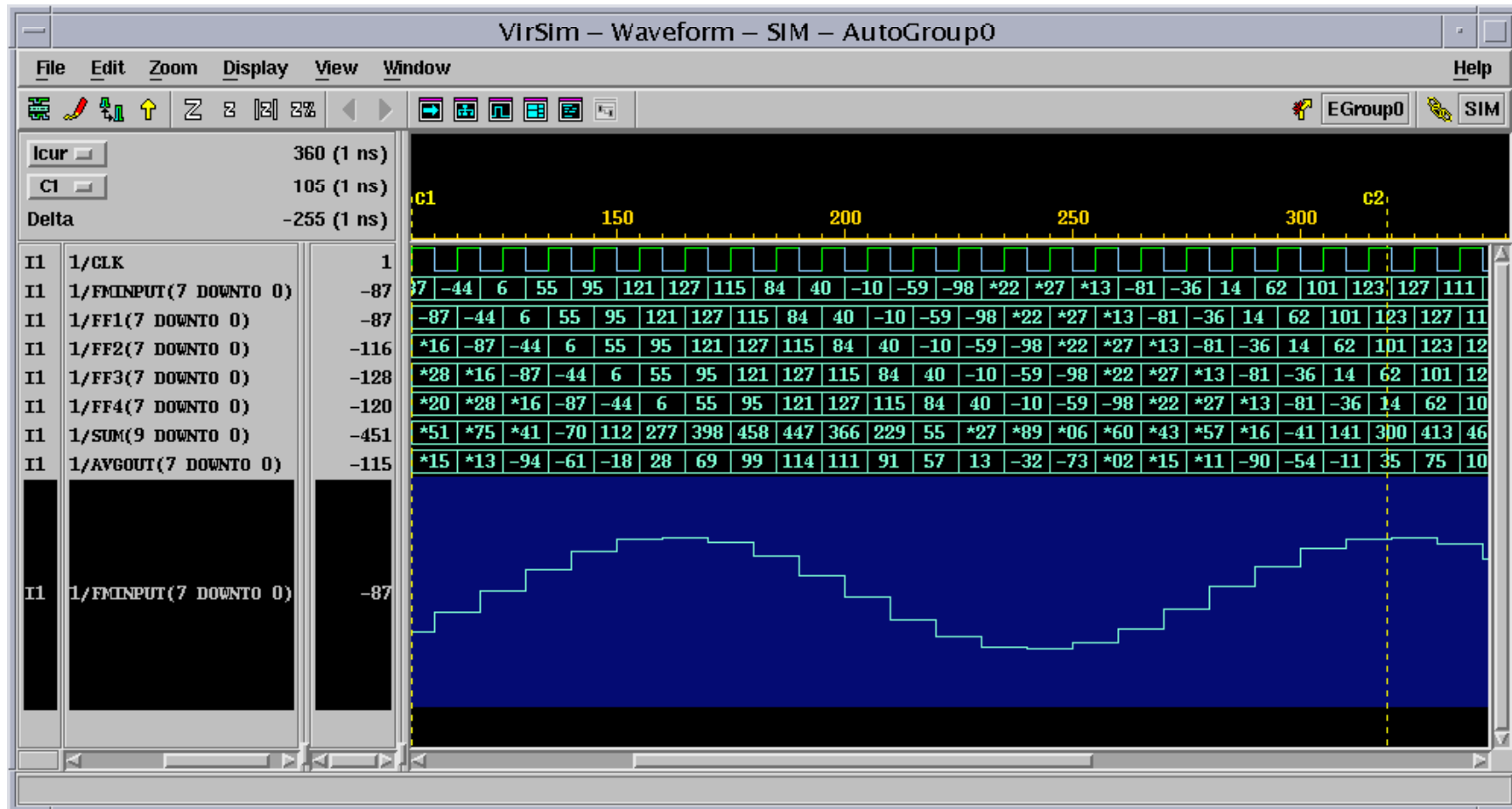

Synthesized Circuit

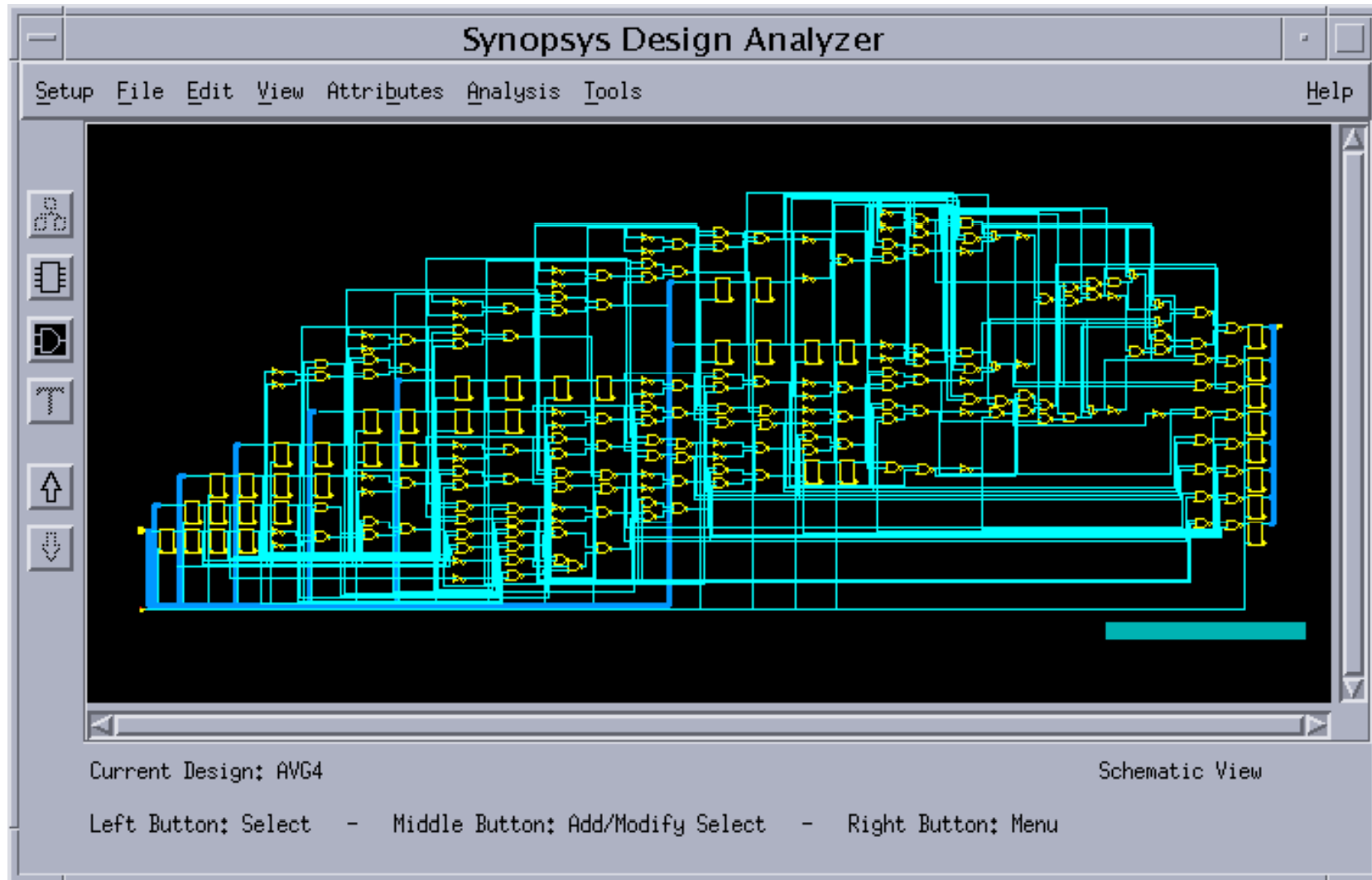

XILINX VP70 FLOORPLAN

