

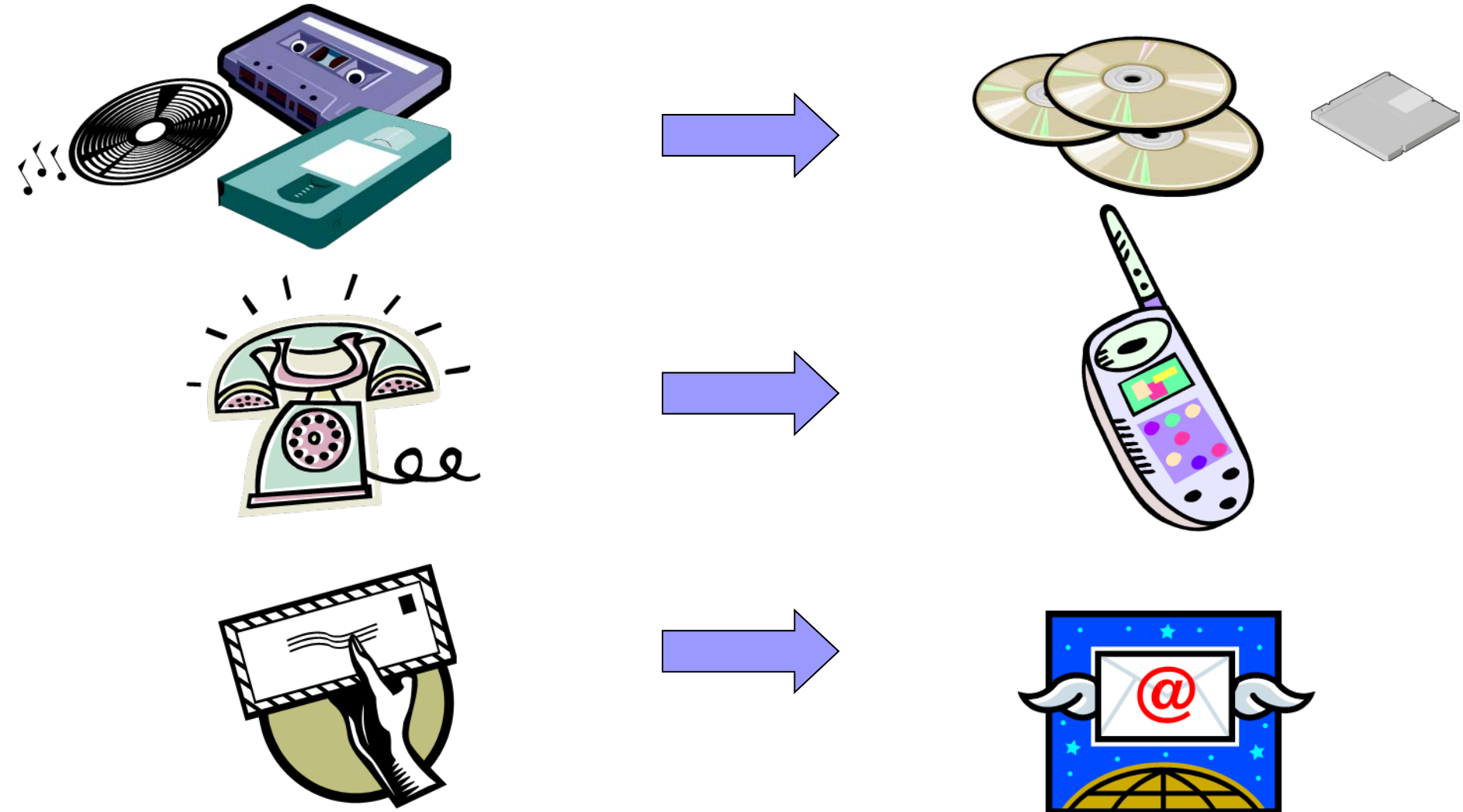

Digital Signal Processor

Analog to Digital Shift



Digital Signal Processing Applications

- FAX
- Phone
- Personal Computer
- Medical Instruments
- DVD player
- Air conditioner (controller)
- Digital Camera
- MP3 audio
- Car Navigation
- Automobile Control
- And MANY...

What is Analog?, What is Digital?



- Continuous Signal
- Similar to Analog watch
- Processed by Analog Circuit such as OP-amp, RLC circuit



- Discontinuous Signal
- The signal is numeric value such as integer or floating point value
- Processed by Digital Circuit or Digital Signal Processor (Software Programmable)

Is Information lost, if we use Digital Signal?

Analog to Digital Conversion

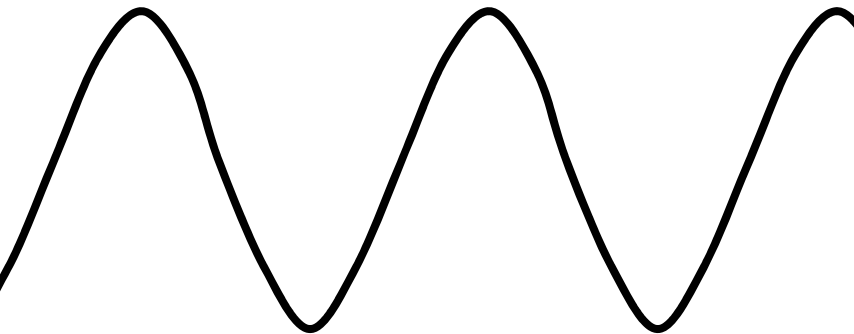

[Analog to Digital Conversion ADC]

- Read the value of the wave every sampling period T_s .
- Value is represented in digital bits.

Continuous
time t

Analog
to Digital
Converter

[Shannon Sampling Theorem]

- If, Sampling frequency $F_s > 2 \cdot F_t$
(F_t : maximum signal frequency)
- Then, Original Analog wave can be re-covered from the sampled signal
- No information loss

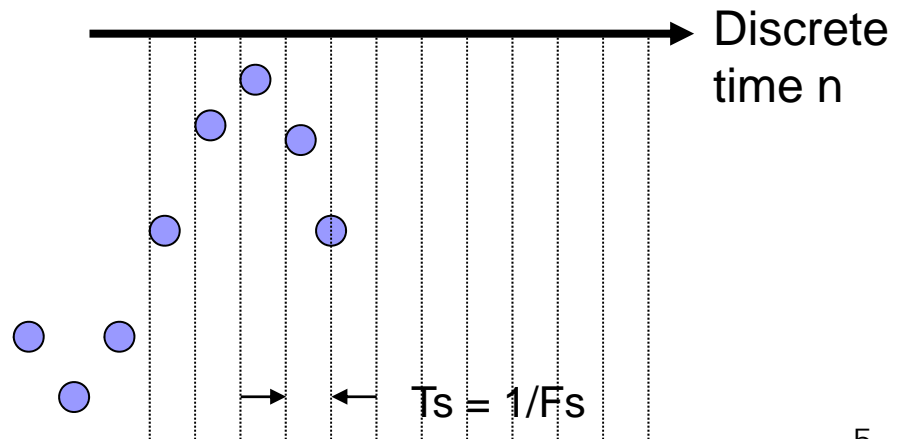

Why Digital Signal Processing is getting major?

- If we use digital values, Any mathematical computation can be realized by Digital Circuit and/or Digital Signal Processor (computer).
- In another word, Any innovative mathematical algorithm can be applied to real life by Digital Technology.
 - This is the reason why I love digital.
- Analog implementation has many limitations.
- Such Heavy digital computation can be processed by Semiconductor Devices such as LSI, FPGA, DSPs.
- Remember OFDM processing (FFT), Such complicated algorithm can only be implemented by Digital Technology.

$$\begin{aligned} u\left(\frac{k}{Nf_0}\right) &= \sum_{n=0}^{N-1} d_n \cdot e^{j2\pi n f_0 \frac{k}{Nf_0}} = \sum_{n=0}^{N-1} d_n \cdot e^{j\frac{2\pi nk}{N}} \\ &= \sum_{n=0}^{N-1} d_n \cdot \left(e^{j\frac{2\pi}{N}}\right)^{nk} \quad (k = 0, 1, 2, \dots, N-1) \end{aligned}$$

Digital Signal Processing Applications

1. Most famous: Data compression and de-compression
 - DVD has 133 minutes video data in One-layer.
 - Compression method is MPEG2
 - If there is no compression technology, only 35 second video can be stored in DVD one-layer.
2. Digital Filter
 - Remove some components of signal (noise, other frequency) from source signal
3. Noise or Echo cancel
4. Error Correction
5. Modulation and Demodulation for wireless communication

But, Human interface is Analog

Example: Voice Processing

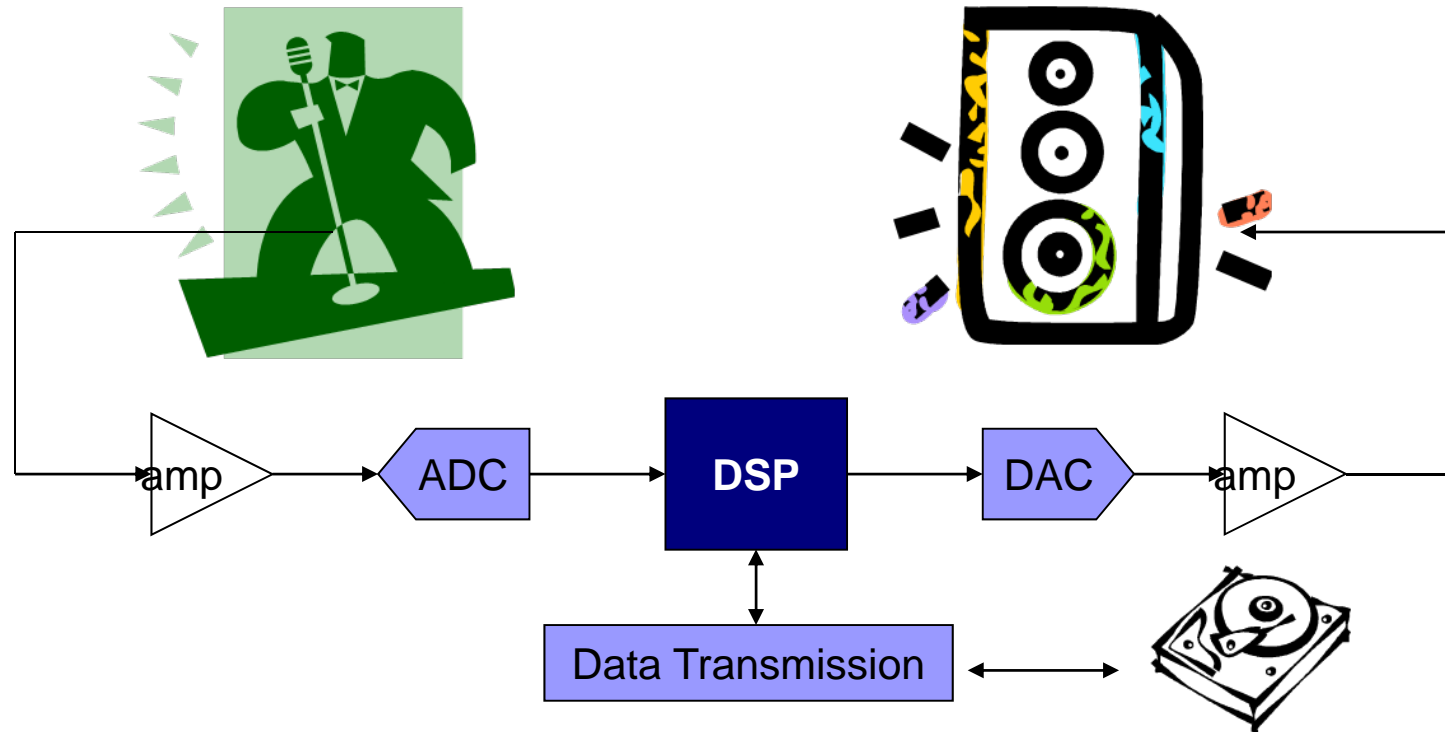

System components

1. Amplifier : Analog Signal control
 - Gain, Noise reduction, Power
2. ADC: Analog to Digital Converter
3. DAC: Digital to Analog Converter
4. DSP: Digital Signal Processor
5. Data Transmission: Data can be Stored in Memory, HDD.

SYSTEM NEEDS BOTH ANALOG and DIGITAL device!

TI 6713 DSK

CODEC
ADC, DAC

Voice, Speaker Interface

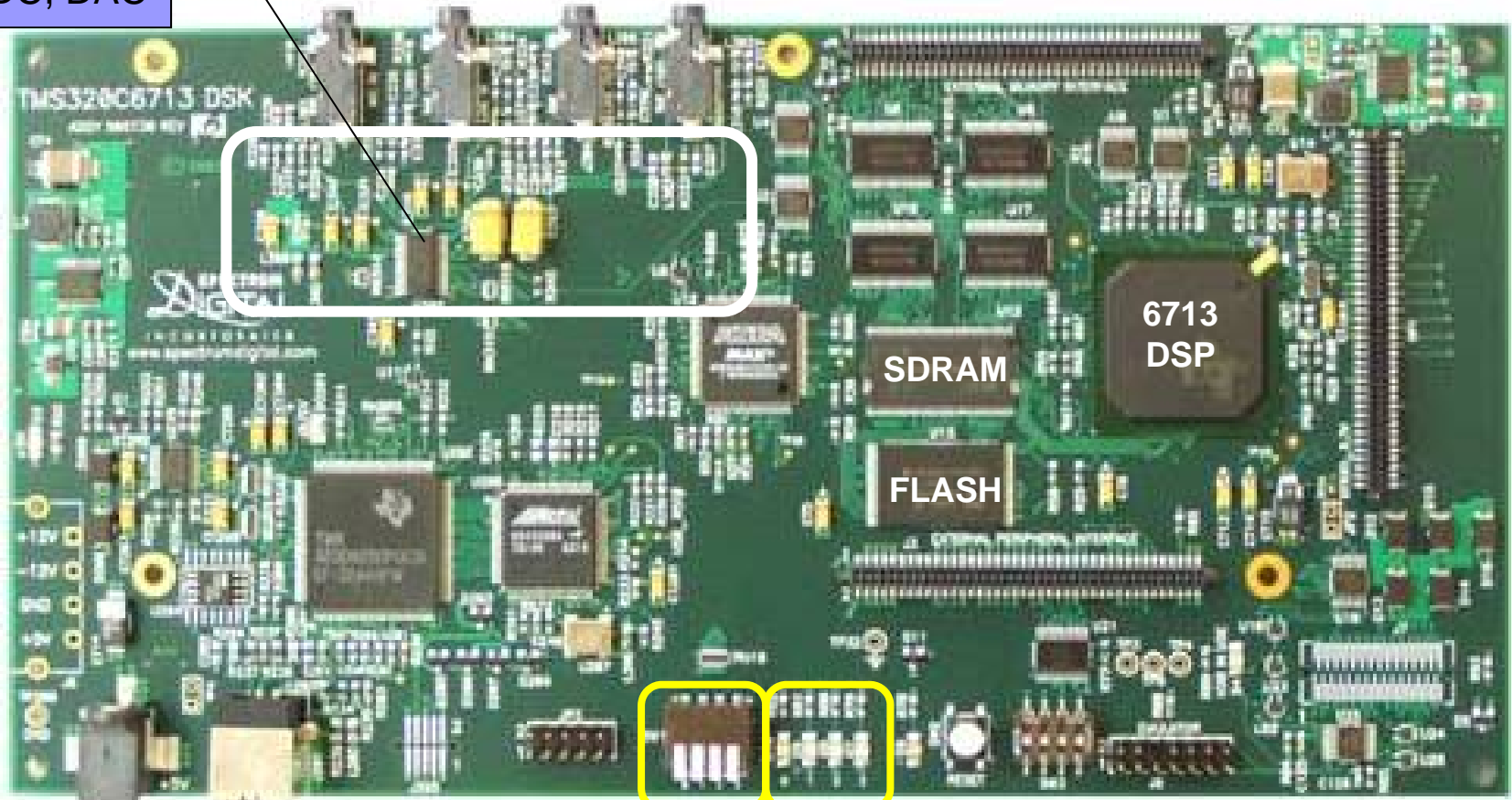

USB
PC-interface

DIP
Switch

LED

DSK6416 Block Diagram

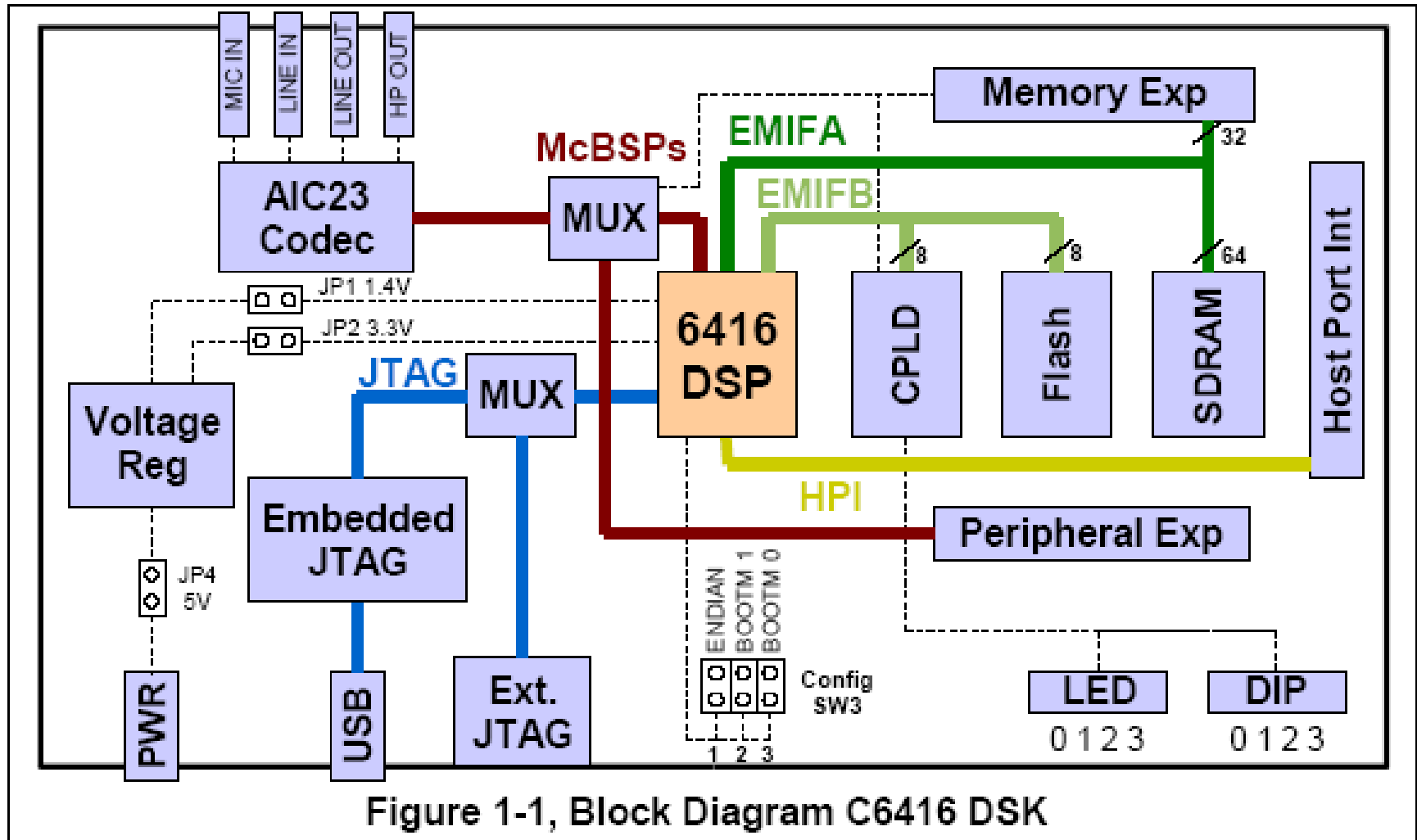

TI C6000 family Architecture

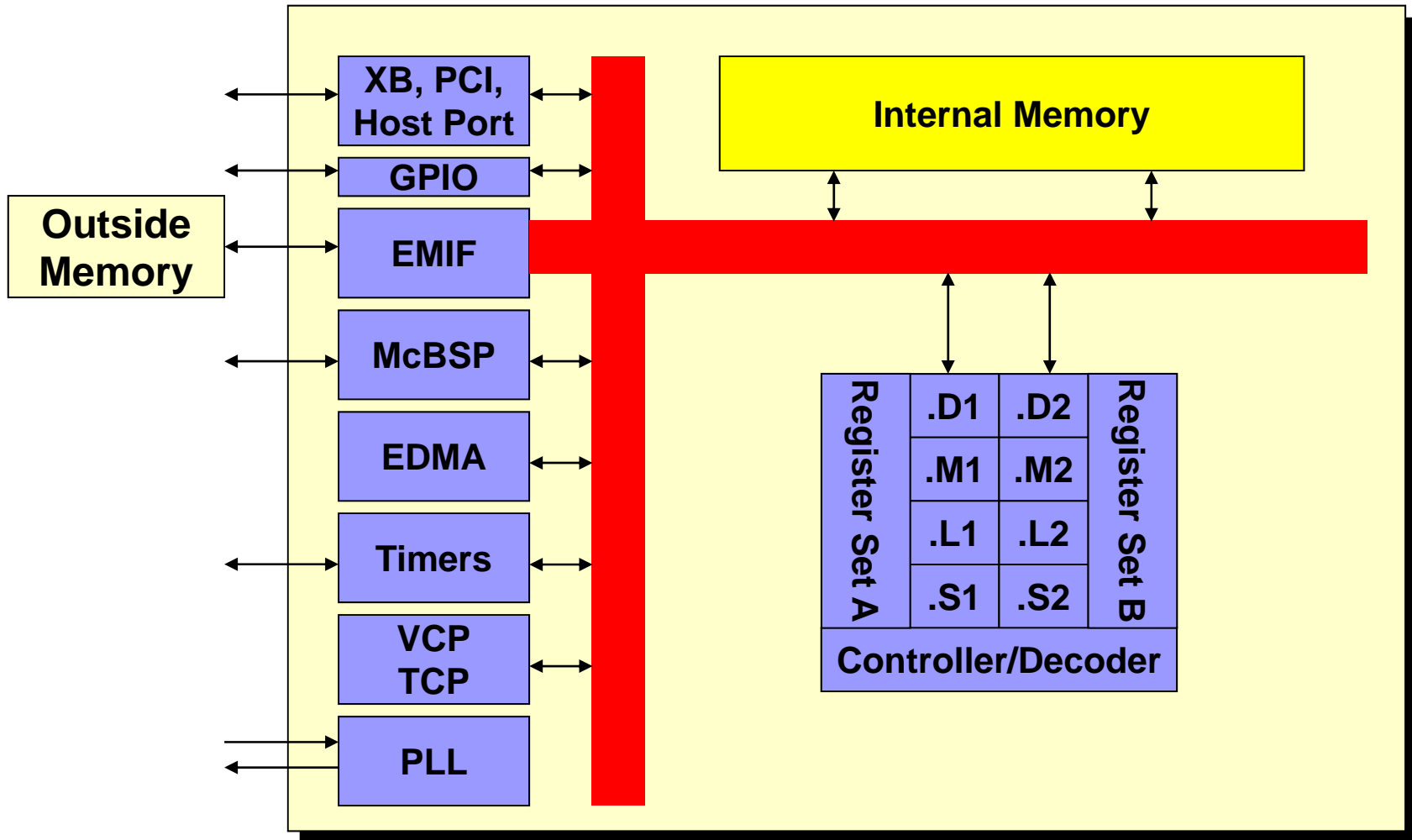

DSP CHIP

TI C6000 family Architecture

1. EMIF External Memory Interface
 - Connect to outside memory such as SDRAM, Flash
2. McBSP Serial Interface
 - Connect to Microphone, Speaker thru DAC, ADC
3. GPIO General Purpose Interface
4. EDMA Enhanced Direct Memory Access
 - Perform data transfer instead of CPU
 - Let CPU work only for computation
5. Timers count time and make interrupt
6. PLL Phase Locked Loop, CLK generation

Comparison between MPU and DSP

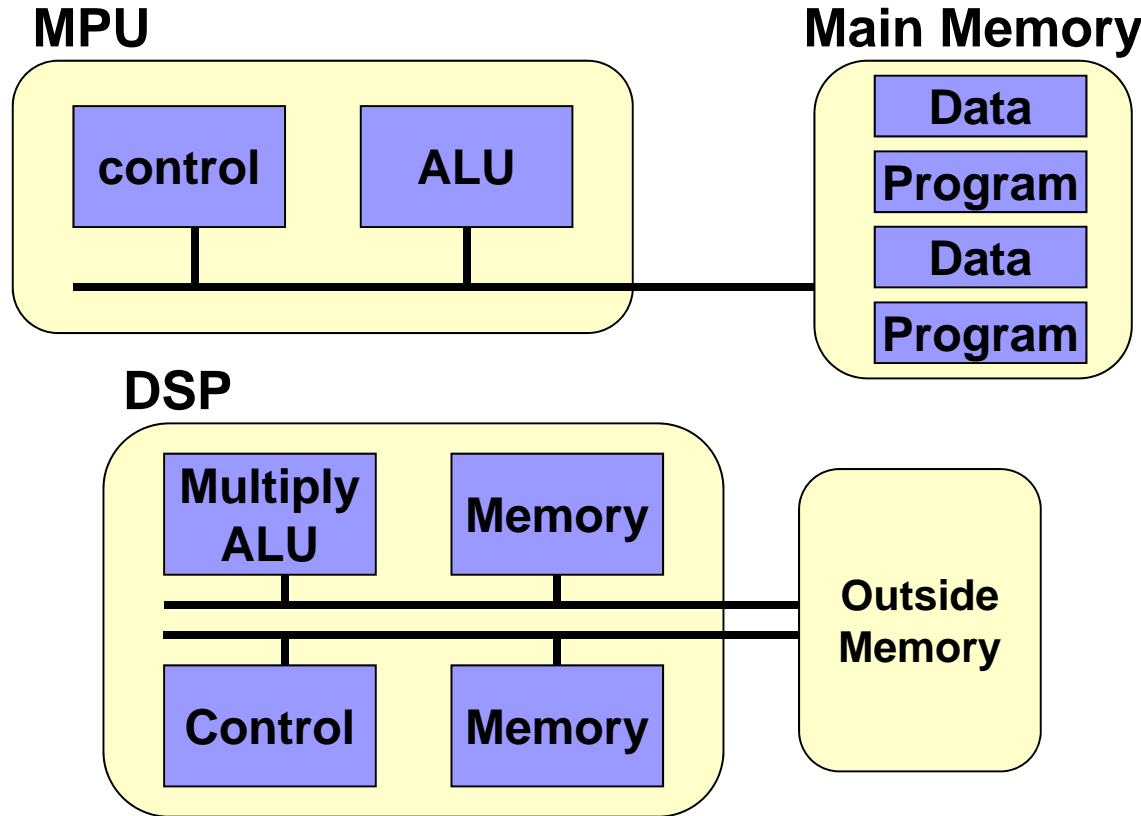

- DSP is strong for Multiply,
- Higher Memory Bandwidth
- Parallel Processing Unit for Parallel computation

What are the typical DSP algorithms?

- The Sum of Products (SOP) is the key element in most DSP algorithms. Multiply and Accumulation (MAC)

Algorithm	Equation
Finite Impulse Response Filter	$y(n) = \sum_{k=0}^M a_k x(n-k)$
Infinite Impulse Response Filter	$y(n) = \sum_{k=0}^M a_k x(n-k) + \sum_{k=1}^N b_k y(n-k)$
Convolution	$y(n) = \sum_{k=0}^N x(k)h(n-k)$
Discrete Fourier Transform	$X(k) = \sum_{n=0}^{N-1} x(n) \exp[-j(2\pi / N)nk]$
Discrete Cosine Transform	$F(u) = \sum_{x=0}^{N-1} c(x).f(x).\cos\left[\frac{\pi}{2N}u(2x+1)\right]$

Some DSP Parameter

Parameter	TMS320C6211 (@150MHz)	TMS320C6711 (@150MHz)
Arithmetic format	32-bit	32-bit
Extended floating point	N/A	64-bit
Extended Arithmetic	40-bit	40-bit
Performance (peak)	1200MIPS	1200MFLOPS
Number of hardware multipliers	2 (16 x 16-bit) with 32-bit result	2 (32 x 32-bit) with 32 or 64-bit result
Number of registers	32	32
Internal L1 program memory cache	32K	32K
Internal L1 data memory cache	32K	32K
Internal L2 cache	512K	512K

Some DSP Parameter (2)

Parameter	TMS320C6211 (@150MHz)	TMS320C6711 (@150MHz)
I/O bandwidth: Serial Ports (number/speed)	2 x 75Mbps	2 x 75Mbps
DMA channels	16	16
Multiprocessor support	Not inherent	Not inherent
Supply voltage	3.3V I/O, 1.8V Core	3.3V I/O, 1.8V Core
Power management	Yes	Yes
On-chip timers (number/width)	2 x 32-bit	2 x 32-bit
Cost	US\$ 21.54	US\$ 21.54
Package	256 Pin BGA	256 Pin BGA
External memory interface controller	Yes	Yes
JTAG	Yes	Yes

Interrupts

- Interrupts are used to interrupt normal program flow so that the CPU can respond to events.
- The events can occur at anytime.

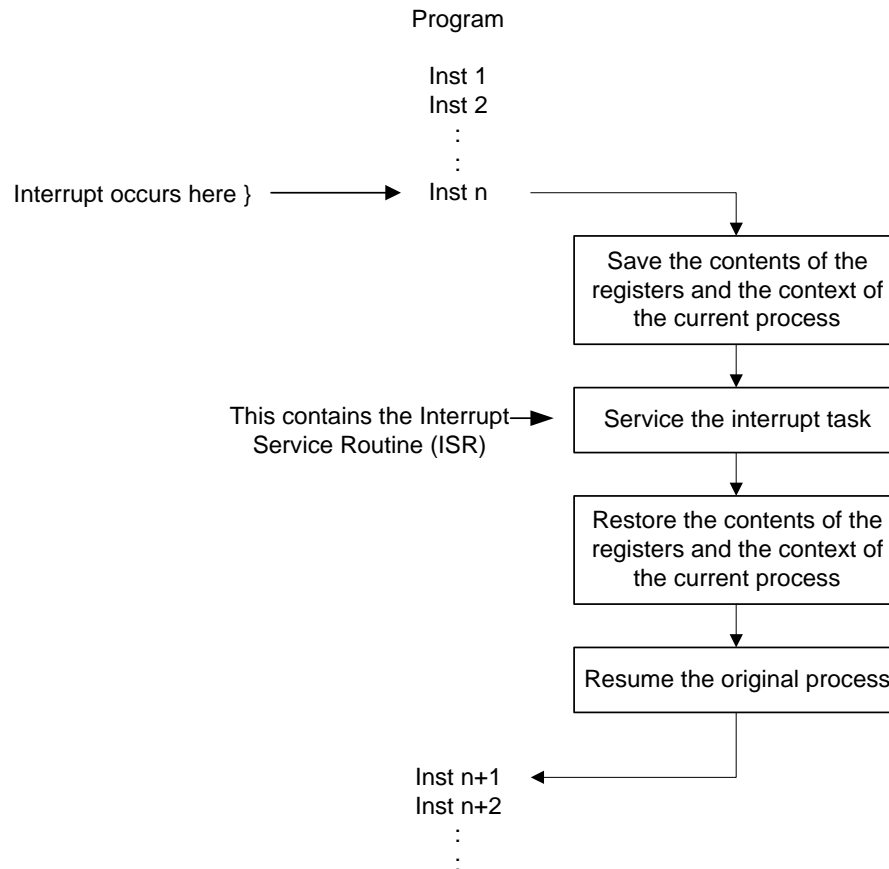

Normal Computer Operation

- Instruction indicated by Program Counter is executed.

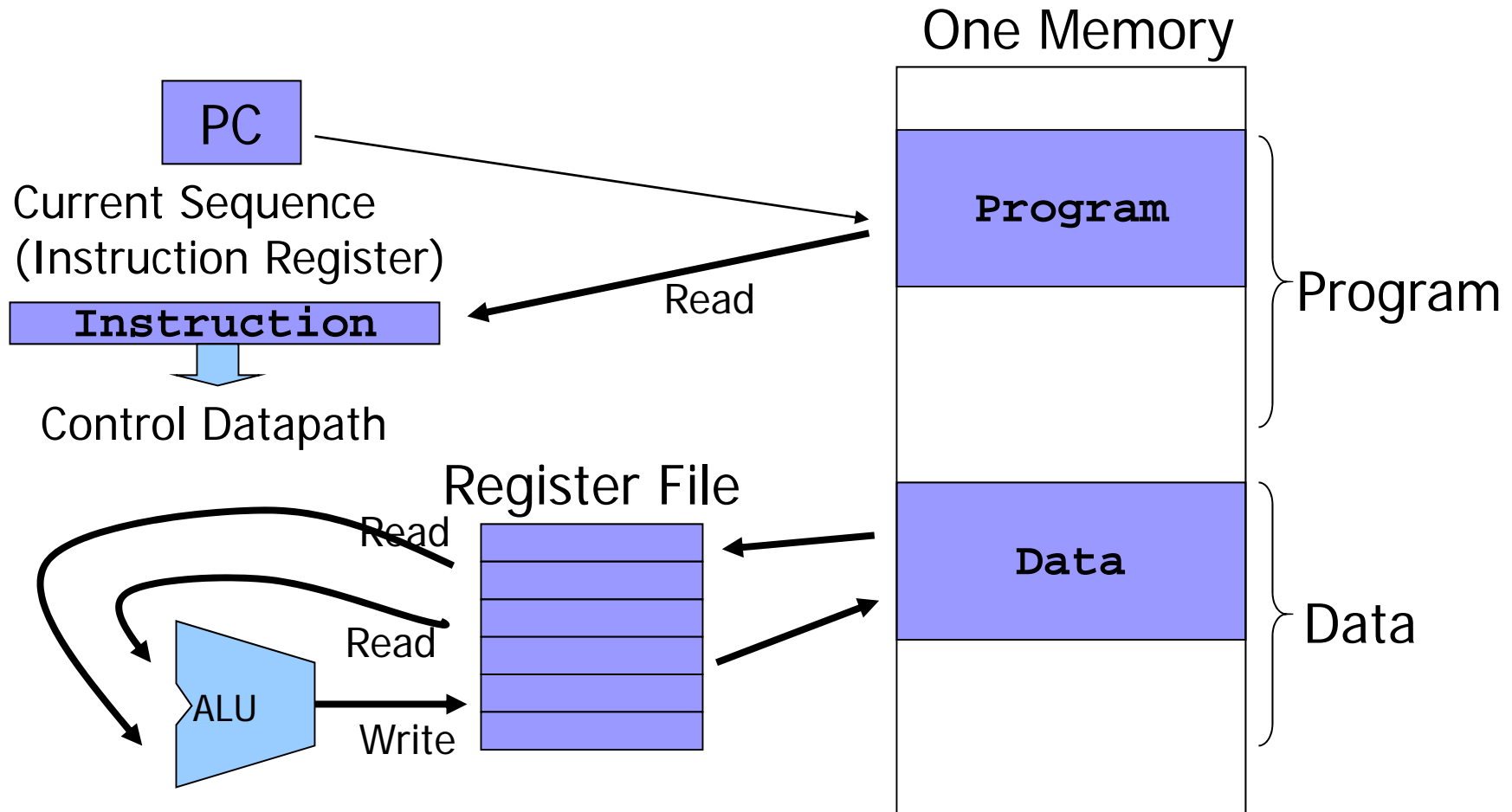

Interrupted Operation

- By Interrupt signal, PC suddenly indicates Interrupt Service Program

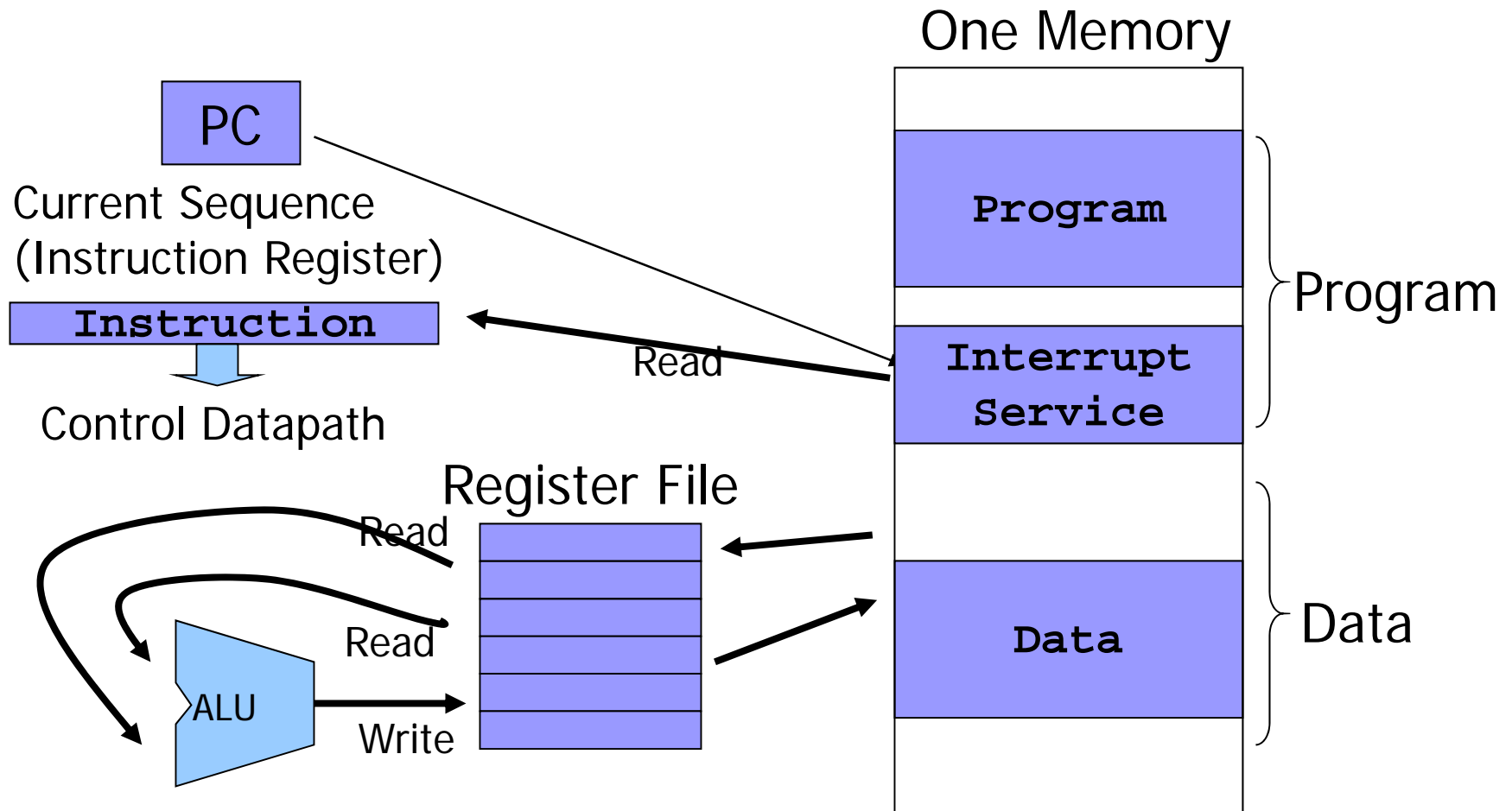

The Need for a DMA

- There are two methods for transferring data from one part of the memory to another, these are using:
 - (1) CPU.
 - (2) DMA.
- If a DMA is used then the CPU only needs to configure the DMA. Whilst the transfer is taking place the CPU is then free to perform other operations.

Introduction to the EDMA

- The 'C6211/C6711 on-chip EDMA controller allows data transfers between the level two (L2) cache memory controller and the device peripherals.
- These transfers include:
 - Cache servicing.
 - Non-cacheable memory accesses.
 - User programmed data transfers.
 - Host accesses.

EDMA Interface

The EDMA allows data transfer to/from any addressable memory spaces.

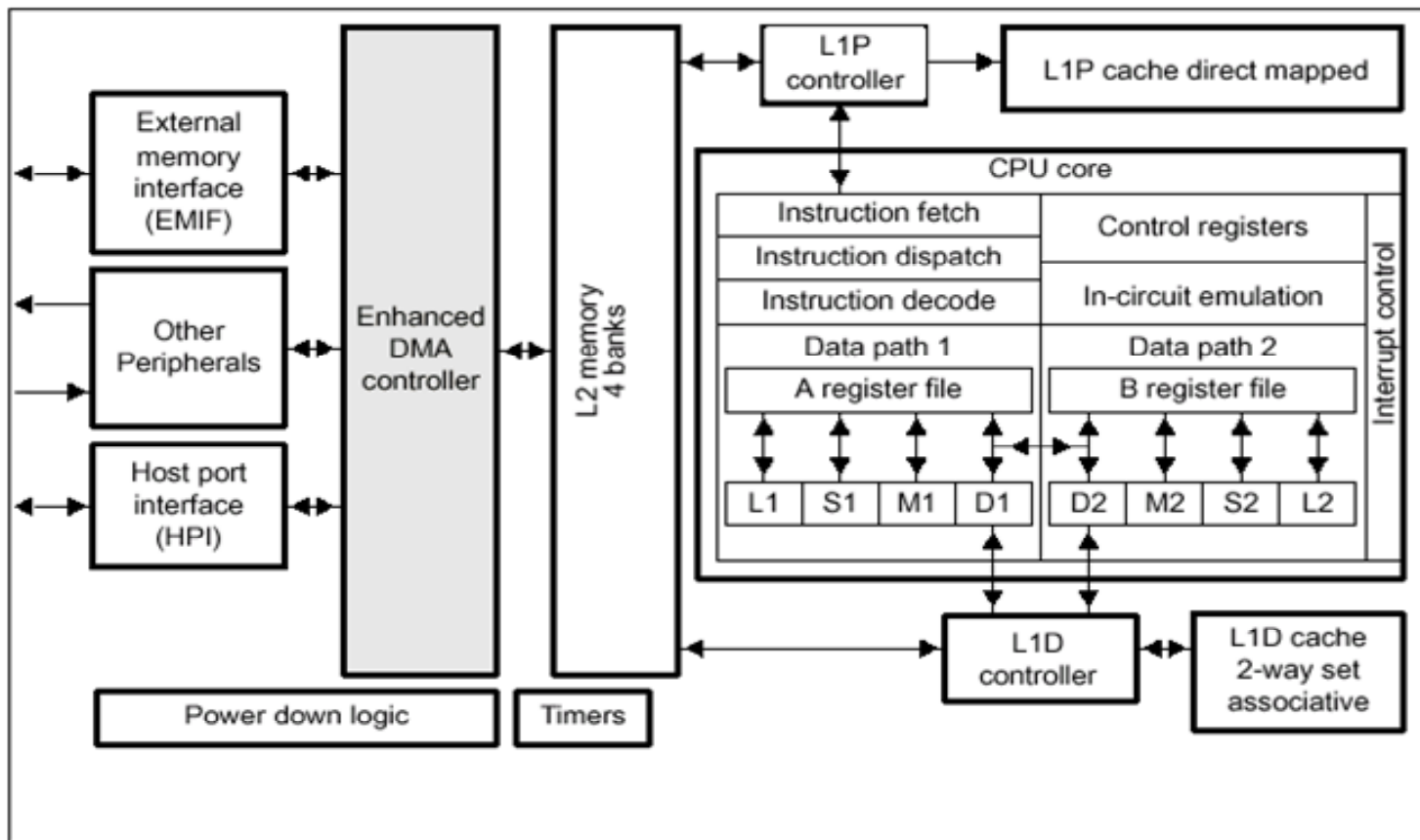

EDMA Functionality

- The data transfer is performed with zero overhead.
- It is transparent to the CPU which means that the EDMA and CPU operations can be independent.
- However, if the EDMA and CPU both try to access the same memory location arbitration will be performed by the program memory controller.

Audio Thru Example

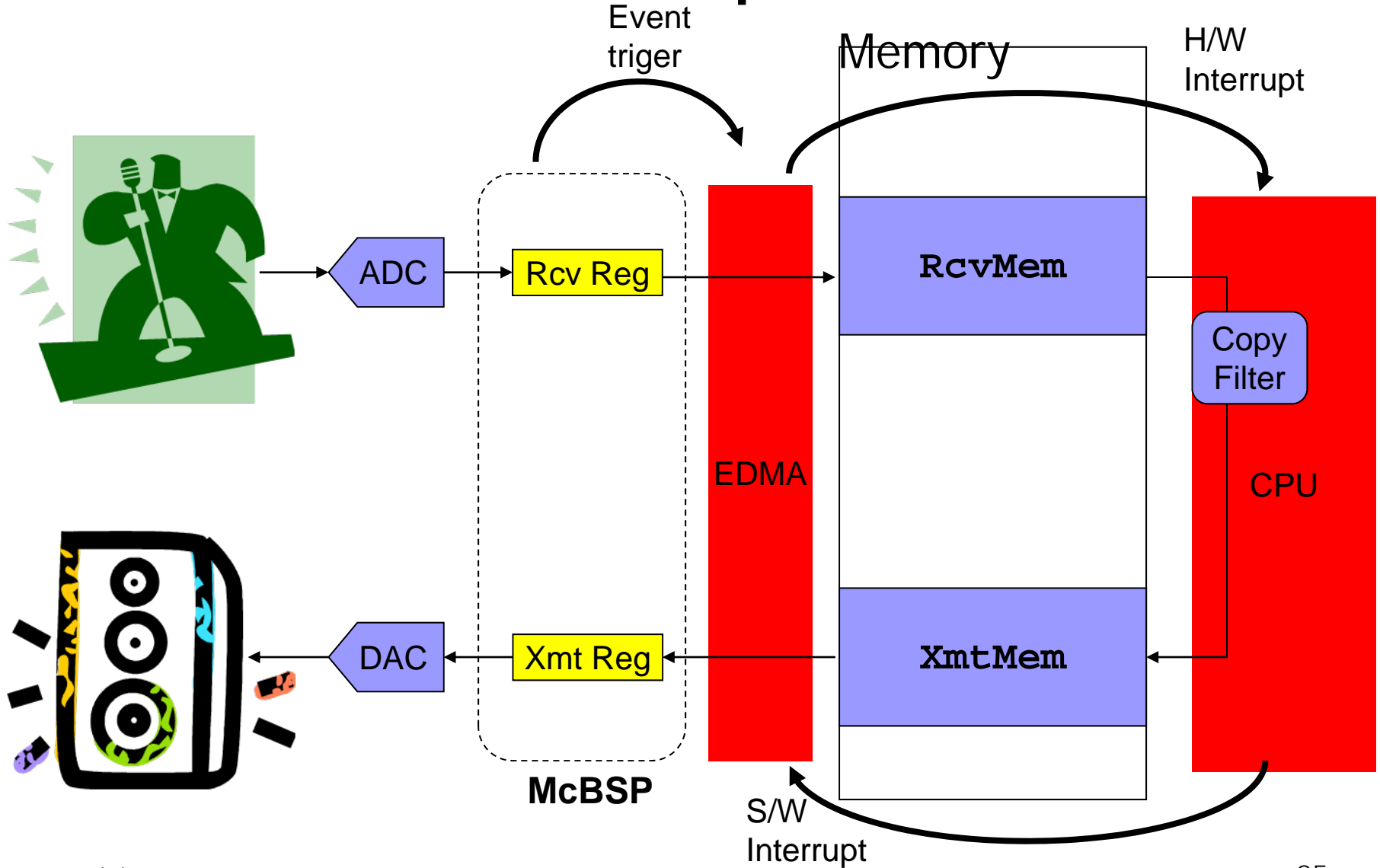

Audio Case

- CD sampling frequency $F_s = 44.1\text{KHz}$
- $T_s = 22.6\mu\text{s}$

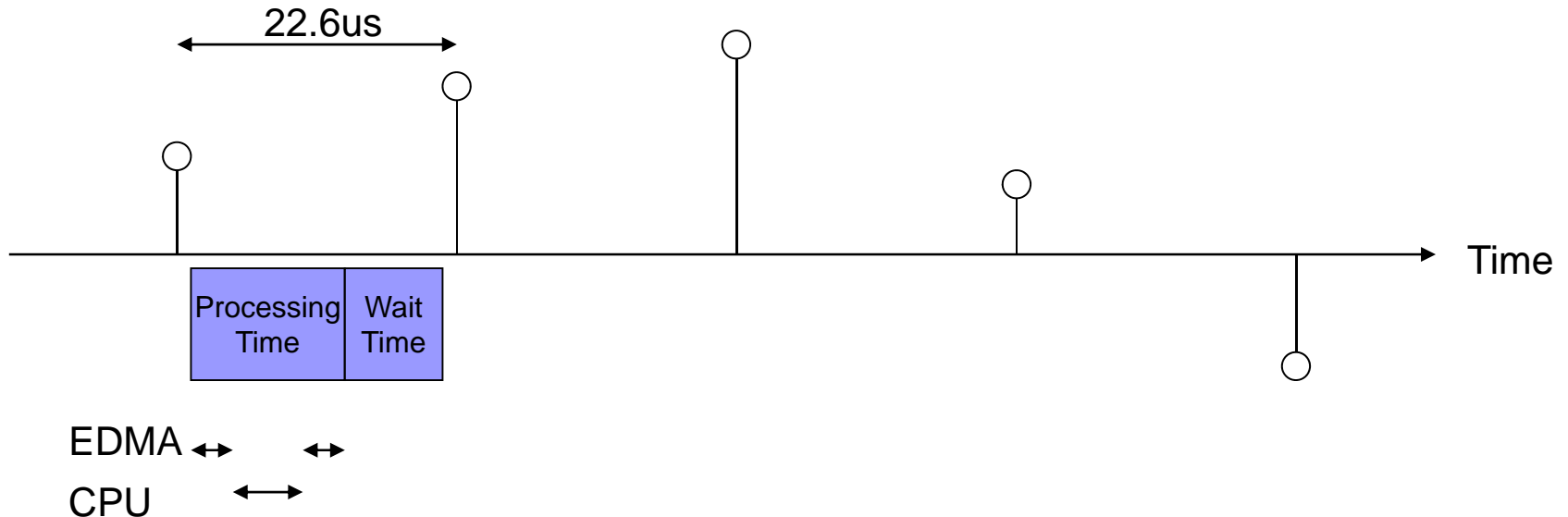

Some TI DSPs

- **TMS320C64x:** The C64x fixed-point DSPs offer the industry's highest level of performance to address the demands of the digital age. At clock rates of up to 1 GHz, C64x DSPs can process information at rates up to 8000 MIPS with costs as low as \$19.95. In addition to a high clock rate, C64x DSPs can do more work each cycle with built-in extensions. These extensions include new instructions to accelerate performance in key application areas such as digital communications infrastructure and video and image processing.
- **TMS320C62x:** These first-generation fixed-point DSPs represent breakthrough technology that enables new equipments and energizes existing implementations for multi-channel, multi-function applications, such as wireless base stations, remote access servers (RAS), digital subscriber loop (xDSL) systems, personalized home security systems, advanced imaging/biometrics, industrial scanners, precision instrumentation and multi-channel telephony systems.
- **TMS320C67x:** For designers of high-precision applications, C67x floating-point DSPs offer the speed, precision, power savings and dynamic range to meet a wide variety of design needs. These dynamic DSPs are the ideal solution for demanding applications like audio, medical imaging, instrumentation and automotive.